

IDAHO MANUFACTURED HOME INSTALLATION STANDARD



January 1, 2004 Edition

State of Idaho
Division of Building Safety
Manufactured Housing Section

Idaho Manufactured Housing Association

IDAHO MANUFACTURED HOME INSTALLATION STANDARD

Developed cooperatively by the

STATE OF IDAHO
DIVISION OF BUILDING SAFETY
MANUFACTURED HOUSING SECTION
1090 East Watertower St.
MERIDIAN, IDAHO 83642

and the

IDAHO MANUFACTURED HOUSING ASSOCIATION
P.O. BOX 8605
BOISE, IDAHO 83707

January 1, 2004 Edition

Copies of this standard may be obtained from the
Idaho Manufactured Housing Association.

A current copy of this standard is also on file
and can be reviewed or obtained from the
Office of the Idaho Division of Building Safety.

TABLE OF CONTENTS

LIST OF FIGURES	xv
CHAPTER 1	
GENERAL	1
000. LEGAL AUTHORITY.....	1
001. TITLE AND SCOPE.....	1
002. WRITTEN INTERPRETATIONS.....	1
003. ADMINISTRATIVE APPEALS.....	1
004. MINIMUM.....	1
005. FIGURES.....	1
006. LICENSING.....	1
CHAPTER 2	
PERMITS AND INSPECTIONS	3
201. PERMITS.....	3
01. Installation and Alteration Permits	3
02. Alterations.....	3
03. Multiple Permits	3
04. Fees.....	3
202. PLAN REVIEWS.....	3
01. Plans.....	3
203. INSPECTIONS.....	3
01. Local.....	3
02. State.....	3
03. Notification.....	3
04. Installer.....	3
204. INSPECTION CRITERIA.....	3
01. Site Inspection.....	3
02. Installation Inspection	4
03. Utilities Inspection	4

TABLE OF CONTENTS

CHAPTER 3	
GENERAL INSTALLATION STANDARDS	7
301. GENERAL.....	7
01. Content.....	7
02. Installation Standard.....	7
03. Snow Loads.....	7
04. Unique Installations.....	7
05. Manufacturer's Installation Instructions.....	9
06. Unusual Installations.....	9
07. Basic Requirement.....	9
08. Chassis Removal.....	9
09. Underfloor Ventilation.....	9
10. Separation From Ground.....	9
11. Close Up.....	9
12. Compliance.....	9
13. Approval.....	9
14. Temporary Placement.....	9
302. SITE PREPARATION.....	9
01. Suitability of Site.....	9
02. Unforeseen Factors.....	9
03. Grading.....	10
04. Erosion.....	10
05. Site.....	10
06. Frost Line.....	10
07. Vapor Retarder.....	10
303. APPROVED INSTALLATION MATERIALS AND COMPONENTS.....	10
01. Component and Materials Specifications.....	10
02. Testing.....	11
304. MARRIAGE LINE CONNECTIONS.....	11
01. General.....	11
02. Shimming.....	11
03. Ridge Beam Connections.....	11
04. Floor Connections.....	11
05. End Wall and Interior Wall Connections.....	13
06. Lag Bolts.....	13
07. Sealing.....	13
08. Patching.....	13

TABLE OF CONTENTS

305.	FLOOD RESISTANCE.....	13
01.	Location.....	13
02.	Installation.....	13
03.	Elevation.....	13
04.	Underfloor Enclosures.....	13
306.	EGRESS REQUIREMENTS.....	14
01.	Egress.....	14
02.	Inspection Approval.....	14
03.	Stairs.....	15
04.	Permanent Construction Requirements.....	15
CHAPTER 4		
STANDARD SET INSTALLATION STANDARDS.....		17
401.	GENERAL.....	17
01.	Content.....	17
02.	Frost Line.....	17
402.	APPROVED INSTALLATION MATERIALS AND COMPONENTS.....	17
01.	Footings.....	17
02.	Block Piers.....	19
03.	Block Pier Caps.....	19
04.	Block Pier Shims.....	21
05.	Block Pier Wedges.....	21
06.	Prefabricated Piers.....	21
07.	Other piers.....	21
08.	Component and Materials Specifications.....	21
09.	Testing.....	21
403.	INSTALLATION SUPPORT REQUIREMENTS.....	21
01.	Main Frame Supports.....	21
02.	Perimeter Supports.....	22
03.	Marriage Line Supports.....	23
	Table 400-A.....	26
04.	Height of Installation.....	27
404.	ANCHORING.....	27
01.	Anchoring.....	27
02.	Loads.....	27
03.	Installation Instructions.....	28
04.	Testing.....	28

TABLE OF CONTENTS

05.	Ties.....	28
06.	Spacing.....	29
07.	Certification.....	29
08.	Alternate anchoring systems.....	29
 CHAPTER 5		
PERMANENT FOUNDATION INSTALLATION STANDARDS.....		31
501.	GENERAL.....	31
01.	Content.....	31
02.	Frost Line.....	31
502.	APPROVED INSTALLATION MATERIALS AND COMPONENTS.....	31
01.	Footings.....	31
02.	Block Piers.....	33
03.	Block Pier Caps.....	33
04.	Block Pier Shims.....	33
05.	Block Pier Wedges.....	34
06.	Prefabricated Piers.....	34
07.	Other piers.....	34
503.	INSTALLATION SUPPORT REQUIREMENTS.....	34
01.	Main Frame Supports.....	34
02.	Perimeter Supports.....	35
03.	Marriage Line Supports.....	354
Table 500-A.....		37
04.	Height of Installation.....	38
504.	PERMANENT FOUNDATIONS.....	38
01.	Permanent Foundation.....	38
02.	Foundations for Existing Home.....	44
03.	Basement Perimeter Support Foundation.....	45
04.	Grading.....	46
05.	Drainage.....	46
06.	Real Property Designation.....	46
07.	Permits and Inspections.....	46
506.	ANCHORING.....	46
01.	Anchoring.....	46
02.	Loads.....	46
03.	Ties.....	47
04.	Spacing.....	47
05.	Certification.....	47

TABLE OF CONTENTS

06.	Alternate anchoring systems	47	
CHAPTER 6			
ELECTRICAL CONNECTIONS.			49
601.	GENERAL.	49	
01.	Installation.	49	
602.	ELECTRICAL FEEDER CONNECTIONS.	49	
01.	Power Supply.	49	
603.	SERVICE EQUIPMENT CONNECTION.	49	
01.	Service Equipment on Manufactured Home	49	
02.	Service Clearances	49	
604.	ELECTRICAL CROSSOVER CONNECTIONS.	49	
01.	Crossover Connection.	49	
02.	Chassis Bonding	49	
605.	ELECTRICAL EQUIPMENT.	51	
01.	Shipped Loose Equipment	51	
02.	Bonding Strap Removal	51	
606.	ELECTRICAL TESTING.	51	
01.	Testing.	51	
CHAPTER 7			
PLUMBING CONNECTIONS.			53
701.	GENERAL.	53	
01.	Connections.	53	
02.	Installer.	53	
03.	Location.	53	
04.	Permits.	53	
702.	SHIP-LOOSE PLUMBING.	53	
01.	Ship-Loose Plumbing	53	
703.	WATER CONNECTIONS.	53	
01.	Water Connections.	53	
02.	Material.	53	
03.	Water Valve Access.	54	
04.	Water Utility Size	54	

TABLE OF CONTENTS

704. DRAIN AND SEWER CONNECTIONS.....	54
01. Drain Connection.....	54
02. Sewer Clean out Access.....	56
705. PLUMBING ASSEMBLY.....	56
706. PLUMBING TESTS.....	57
01. Water Test.....	57
02. Drain Test.....	58
CHAPTER 8	
MECHANICAL CONNECTIONS.....	59
801. GENERAL.....	59
01. Permits.....	59
02. Installations.....	59
802. MECHANICAL EQUIPMENT.....	59
01. Original Installations.....	59
02. After Market Installations.....	59
03. Equipment Support.....	59
04. Prohibited Installations.....	59
05. Condensation Drains.....	59
803. CROSSOVER DUCTS.....	59
01. General.....	59
02. Crossover Ducts.....	59
804. APPLIANCE VENTING.....	62
01. Venting.....	62
02. Dryer Exhaust Vents.....	62
CHAPTER 9	
ACCESSORY BUILDINGS AND STRUCTURES.....	65
901. GENERAL.....	65
01. Standards.....	65
902. UNDERFLOOR ENCLOSURES.....	65
01. Requirement.....	65
02. Skirting.....	65
03. Perimeter Foundations.....	65

TABLE OF CONTENTS

903. UNDERFLOOR VENTILATION.....	65
01. Requirement	65
904. UNDERFLOOR ACCESS.....	67
01. Requirement	67
02. Skirting Access	67
03. Foundations and Ground Level Access	67
04. Floor Access.....	68
05. Stairway Access	68
905. CARPORTS & AWNINGS.....	68
01. Accessories.....	68
02. Site Built	68
03. Prefabricated.....	68
04. Windows and Doors.....	68
05. Enclosure.....	68
06. Wall Support.....	68
07. Wall Attachment	68
08. Roof Support.....	69
906. PORCHES.....	69
01. Accessory.....	69
02. Self Supportive.....	69
03. Code.....	69
907. ATTACHED GARAGES.....	69
01. Accessory.....	69
02. Self Supportive.....	69
03. Code.....	69
04. Separation.....	69
908. RAMADAS.....	72
01. Accessory.....	72
02. Clearance.....	72
03. Self Supportive.....	72
04. Enclosures.....	72
05. Chimneys and Flues	72
06. Egress and Exit.....	72
909. ACCESS & EGRESS.....	72
01. Requirement	72
02. Obstructions.....	72

TABLE OF CONTENTS

03.	Enclosed Exit Doors.....	72	
04.	Original Exit Door.....	72	
05.	Prohibited Construction.....	73	
910.	DECKS, PORCHES, LANDINGS, STAIRS, RAMPS & GUARDRAILS.....	73	
01.	Construction Standard.....	73	
02.	Attachment to Manufactured Home.....	73	
03.	Required Installations.....	73	
CHAPTER 10			
HEAT PRODUCING APPLIANCES.....			75
1001.	GENERAL.....	75	
01.	Listing Requirement.....	75	
02.	Installation Instructions.....	75	
03.	Accessibility.....	75	
04.	Clearance.....	75	
05.	Other Appliances.....	75	
06.	Operating Instructions.....	75	
1002.	RANGES & DRYERS.....	75	
01.	Listed Standards.....	75	
02.	Clearances.....	75	
03.	Dryer Exhaust.....	75	
04.	Range Exhaust Vents.....	75	
1003.	FURNACES, GAS STOVES, WATER HEATERS, & GAS FIREPLACES.....	76	
01.	Appliance Listing.....	76	
02.	Installation.....	76	
03.	Combustion Air.....	76	
04.	Flue Listing.....	76	
05.	Appliance Compartment.....	76	
06.	Securement.....	76	
1004.	SOLID FUEL BURNING FIREPLACES & STOVES.....	77	
01.	Listing Standard.....	76	
02.	Minimum Stove Construction Requirements.....	76	
03.	Labeling.....	76	
04.	Installation.....	77	
1005.	PELLET FIRED APPLIANCES.....	77	
01.	Installations.....	77	

TABLE OF CONTENTS

DEFINITIONS	81
ACRONYMS AND ABBREVIATIONS	86
SUBJECT INDEX	87
FIGURE INDEX	91
SUPPLEMENTAL INFORMATION NOT A PART OF THE STANDARD	
Local Government Contacts.....	Supplement Page 1

This page intentionally blank

LIST OF FIGURES

Figure 301.1	Standard Set.	8
Figure 301.2	Permanent Foundation Set.	8
Figure 304.1	Ridge Beam Bolt Connection	12
Figure 304.2	Floor Connection w/ Lag Screw	12
Figure 304.3	Floor Connection w/ Clips	12
Figure 304.4	Interior Wall Connections	12
Figure 304.5	End Wall Connections	12
Figure 306.1	Stairs.	14
Figure 402.1	Precast Concrete Pier Pad.	18
Figure 402.2	Poured Concrete Pier Pad.	18
Figure 402.3	Double Layer Wood Pier Pad.	18
Figure 402.4	Single Layer Wood Pier Pad	18
Figure 402.5	Wood Pier Pad.	18
Figure 402.6.	Continuous Concrete Footing.	18
Figure 402.7	Typical Concrete Block Pier.	20
Figure 402.8	Typical Double Stack Concrete Block Pier.	20
Figure 402.9	Typical Block Pier Detail	20
Figure 402.10	Typical Prefabricated Pier	20
Figure 403.1	Support System.	22
Figure 403.2	Perimeter Pier w/ Transverse Joists.	24
Figure 403.3	Perimeter Pier w/ Longitudinal Joists	24
Figure 403.4	512 Sq. In. Pier Pad.	24
Figure 403.5	1024 Sq. In. Pier Pad.	24
Figure 406.1	Frame Tie Down Detail	28
Figure 406.2	Main Frame Tie Down Strap Connection	28
Figure 502.1	Precast Concrete Pier Pad.	31
Figure 502.2	Poured Concrete Pier Pad.	31
Figure 502.3	Typical Concrete Block Pier.	32
Figure 502.4	Typical Double Stack Concrete Block Pier.	32
Figure 502.5	Typical Block Pier Detail	32
Figure 502.6	Typical Prefabricated Pier	32
Figure 503.1	Support System.	22
Figure 504.1A	Poured Concrete Permanent Foundation.	39
Figure 504.1B	8" x 8" x 16" Concrete Block Permanent Foundation.	39
Figure 504.1C	Pressure Treated Wood Permanent Foundation.	39
Figure 504.2A	Concrete Foundation Plan.	40
Figure 504.2B	Section Through Concrete Foundation.	40
Figure 504.3A	Building Section	42
Figure 504.3B	Foundation Section Detail	42
Figure 504.3C	Foundation Elevation Detail	42
Figure 504.4A	Cross Section Through Basement.	43
Figure 504.4B	Basement Foundation Plan	43
Figure 505.1	Main Frame Tie Down Strap Connection	47

LIST OF FIGURES

Figure 603.1	Service Conductor Clearances Underground Feeder.	50
Figure 605.1	Ship-Loose Light Installation	50
Figure 605.2	Ship-Loose Fan Installation	50
Figure 703.1	Concealed Water Crossover Connection.	55
Figure 703.2	Exposed Water Crossover Connection.	55
Figure 704.1	Drain Line Connection	55
Figure 802.1	Mechanical Equipment Support	60
Figure 803.1	Crossover Duct Connection.	60
Figure 804.1	Attached Garage Mechanical Vents	63
Figure 804.2	Dryer Duct Installation.	63
Figure 902.1	Underfloor Enclosures.	66
Figure 902.2	Typical Recessed Porch Detail	66
Figure 905.1	Carport Connection.	70
Figure 906.1	Porch Installation.	70
Figure 907.1	Attached Garage.	71
Figure 908.1	Ramada Installation.	71
Figure 1004.1	Wood Stove Installation.	78
Figure 1005.1	Sidewall Ventilation Termination	78

Chapter 1 GENERAL

100. LEGAL AUTHORITY.

In accordance with Section 44-2201(2), Idaho Code, the Idaho Division of Building Safety (herein referred to as Division) is authorized to promulgate rules specifying standardized installation instructions for manufactured homes. These rules constitute a preemptive statewide standard and no other code, standard, or regulation shall be used regarding the installation of manufactured homes, except as provided for in **Subsection 301.04** and **Subsection 304.03.b**.

101. TITLE AND SCOPE.

These rules shall be cited as the "Idaho Manufactured Home Installation Standard" or as "IMHIS." These rules apply to persons engaged in the business of manufacturing, selling, siting, installing, servicing, repairing, altering, or preparing for transport (commonly called 'tear down'), manufactured homes in the state of Idaho. Within this standard the phrase "manufactured home" includes mobile home.

102. WRITTEN INTERPRETATIONS.

There are no written statements which pertain to the interpretation of these standards.

103. ADMINISTRATIVE APPEALS.

There are no provisions for administrative appeal of the requirements outlined herein.

104. MINIMUM STANDARDS.

This standard provides minimum statewide standards for the safety of the consumer, general public, and the owners and occupants of manufactured homes regulated by this standard. This standard may be exceeded by a homeowner, contractor, or dealer, but no jurisdiction shall require a person to exceed this standard, except as permitted by Section 67-6509A, Idaho Code, regarding siting within residential areas.

105. FIGURES.

Every figure used in this standard pertains specifically to the Section(s) or Subsection(s) which references it. Figures will not show every method described by the narrative in the referencing Section or Subsection. They are intended to aid the user of this standard by visually describing requirements of the referencing Section or Subsection. The requirements that are narratively prescribed in the referencing Section or Subsection must be complied with regardless of the specific details which may be shown in the figures. An alternative configuration, design, or technique, which can be shown to comply with the narratively prescribed requirements will be acceptable. Also, an alternative configuration, design, or technique, which can be shown by engineering calculation or demonstrated by experience or testing to meet or exceed the requirements of the associated Section or Subsection, and which is approved by the Division and the Manufactured Home Installation Committee, may be acceptable.

106. LICENSING.

Pursuant to Title 44, Chapter 21, Idaho Code, the regulation and control of those persons engaged in the business of manufacturing, selling, installing, servicing, or preparing for transport (commonly called 'tear down'), manufactured homes is necessary to protect the health and safety of the citizens of Idaho. To that end, it shall be unlawful for any person to engage in business as a manufacturer of manufactured homes, a manufactured home dealer, manufactured home broker, manufactured home installer, manufactured home service company or a manufactured home salesman without being duly licensed as provided for in IDAPA 07.03.11, "Rules Governing Manufactured/Mobile Home

Licensing," Division of Building Safety,
IDAPA 07.03.11.

107. -- 199. RESERVED.

Chapter 2
PERMITS AND INSPECTIONS

201. PERMITS.

01. **Installation and Alteration Permits.** As required by Title 44, Chapter 22, Idaho Code, permits shall be obtained, using application forms furnished by the authority having jurisdiction, before installing a manufactured home on a building site or in a park. This includes manufactured homes set up for display in manufactured home parks, mobile home parks, subdivisions, and residential lots, and that are occupied on a sales lot.

a. **Exception:** Installation permits are not required for unoccupied manufactured homes which are temporarily displayed on a sales lot or are in storage.

02. **Alterations.** No alteration may be made by a dealer or installer which takes a new manufactured home out of compliance with HUD approved designs. No alteration may be done to a new manufactured home without written approval by the manufacturer and an inspection by the Division of Building Safety.

03. **Multiple Permits.** Multiple permits may be required by the authority having jurisdiction when the proposed work involves two (2) or more of the following code areas: installation, structural, electrical, plumbing, or mechanical. Permits are to be obtained prior to the start of proposed work.

04. **Fees.** Permit fees shall be those established by the authority having jurisdiction.

202. PLAN REVIEWS.

01. **Plans.** The authority having jurisdiction may require plans to be submitted before installing a manufactured home and/or constructing additions thereto.

a. Plans shall be of sufficient clarity to indicate the nature and extent of the work proposed.

203. INSPECTIONS.

01. **Local.** Pursuant to Section 44-2202, Idaho Code, all local jurisdictions which have adopted a building code shall issue permits and inspect all manufactured/mobile home installations for the purpose of determining compliance with this standard.

02. **State.** All electrical and plumbing connections shall be inspected by the state or authorized local authority having jurisdiction.

03. **Notification.** Persons involved in doing work shall notify the responsible inspecting agency and that agency shall perform requested inspections within a reasonable time.

04. **Installer.** All installations shall be inspected by a licensed installer or a responsible managing employee (RME) and a copy of such inspection records, using a Division approved form, shall be provided to the homeowner upon completion of the inspection.

204. INSPECTION CRITERIA.

01. **Site Inspection.** It is recommended a "site inspection" be performed by the dealer or his representative and the customer prior to the installation of the manufactured home to verify that:

a. All required installation, structural, and plumbing, permits have been obtained;

b. Minimum setback requirements are being complied with;

- c. Vegetation has been removed from all areas that will be covered by the home, accessory structures, or concrete;
- d. The site has been properly prepared for the home installation.
- e. All concrete footings and foundations have been installed in compliance with this standard;
- f. Site grading and drainage work have been completed in compliance with this standard; and
- g. All aspects of construction which are affected by roof load specifications have been constructed in compliance with this standard using the locally specified roof loads.

02. Installation Inspection. An installation inspection shall be performed by both the local authority having jurisdiction and the licensed installer or responsible managing employee (RME). The inspectors should verify that all the following items, as applicable for the specific installation, have been obtained, provided, constructed, or installed in compliance with this standard and the requirements of the local authority having jurisdiction.

- a. Applicable permits.
- b. Footings.
- c. Foundations.
- d. Vapor barrier.
- e. Footings, particularly with respect to size and spacing.
- f. Piers, particularly with respect to type, size, and spacing.
- g. Multi-section connections.

- h. Weather stripping and weather seals installed on-site.
- i. Exposed structural connections.
- j. Tie-down attachments.
- k. Skirting or permanent foundation.
- l. Underfloor access provisions.
- m. Underfloor ventilation provisions.
- n. Stairs.
- o. Site grading and drainage.
- p. Site installed exterior doors.
- q. Dryer exhaust ducted through skirting or foundation.
- r. Heat tape and pipe insulation.
- s. Duct crossovers, to ensure they have been installed in compliance with this standard and the duct manufacturer's instructions.
- t. Flue, chimney, and vents, particularly with respect to material, size, clearance, connections, and terminations.
- u. Factory installed smoke detectors.
- v. Wood stoves.

03. Utilities Inspection. A utilities inspection shall be conducted by State Plumbing and Electrical Inspectors or the local authority having jurisdiction. The inspectors should verify that all the following items, as applicable for the specific installation, have been obtained, provided, constructed, or installed in compliance with this standard and the requirements of the local authority having jurisdiction.

- a. Plumbing connections.
- b. Shutoff valves.

- c. Water supply utility connection.
- d. Sewer or septic pipe connection.
- e. Fuel gas piping.
- f. Electrical connections.
- g. Electrical service, particularly with respect to type, size, and workmanship.
- h. Air conditioning.
- i. After market electrical or plumbing equipment.

205. -- 299. RESERVED.

This page intentionally blank

Chapter 3 GENERAL INSTALLATION STANDARDS

301. GENERAL.

There are two basic types of installations - standard set and permanent foundation set. See **Figures 301.1** and **301.2**. This Chapter prescribes the general installation requirements which apply to both types. Requirements that specifically apply to standard set homes are prescribed in Chapter 4. Requirements that specifically apply to homes set on permanent foundations are prescribed in Chapter 5. To facilitate the use of this standard, detailed support requirements which are applicable to both types of installations are prescribed in both sections. All design calculations upon which the requirements in Chapters 3, 4, and 5 are based, have been reviewed by an Idaho Registered Professional Engineer for compliance with the Idaho adopted 2000 International Building Code (IBC) (effective January 1, 2003).

01. Content: This Chapter prescribes requirements for:

- a. The siting, and design of manufactured homes;
- b. Joining the sections of multi-section homes;
- c. Flood resistance; and
- d. Access and egress.

The requirements for installation and tie down anchoring are prescribed in Chapters 4 and 5.

02. Installation Standard. The siting and installation requirements contained in this standard are based on a roof live load of thirty to one hundred twenty pounds per square foot (30 to 120 psf), a roof dead load of ten to eighteen pounds per square foot (10 to 18 psf), and a soil bearing capacity of one thousand five hundred pounds per square foot (1,500 psf).

All manufactured homes shall be installed to the minimum requirements of this standard.

a. Manufacturers' installation instructions may be used where specifically permitted in **Subsections 301.04, 304.03.b, 403.03.b and 503.03.b.**

b. Manufactured homes placed temporarily on display, or are in storage and not occupied or intended to be occupied, shall be temporarily placed according to the requirements of **Subsection 301.14.**

03. Roof Snow Loads. New manufactured homes sold in Idaho are required by HUD to be constructed to withstand a minimum of thirty pounds per square foot (30 psf) roof snow load. Some jurisdictions may require a higher roof snow load. The dealer shall verify that roof snow load requirements are being complied with before selling a home in a jurisdiction. Jurisdictions with a higher roof snow load requirement shall provide the dealer, installer, or customer with written notification, signed by the building official, of the site specific roof snow load requirement, prior to the issuance of an installation permit.

04. Unique Installations. Manufactured homes with unique installation requirements not specifically addressed in this standard shall be installed according to the manufacturer's installation instructions. However, the use of those instructions shall be limited to the specific aspects which are unique. Examples of unique installation aspects are: hinged rafters, perimeter floor frames, two storied homes, hinged eaves, add-on roofs, marriage line tie-downs, items identified in a HUD and DAPIA approved Alternate Construction (AC)

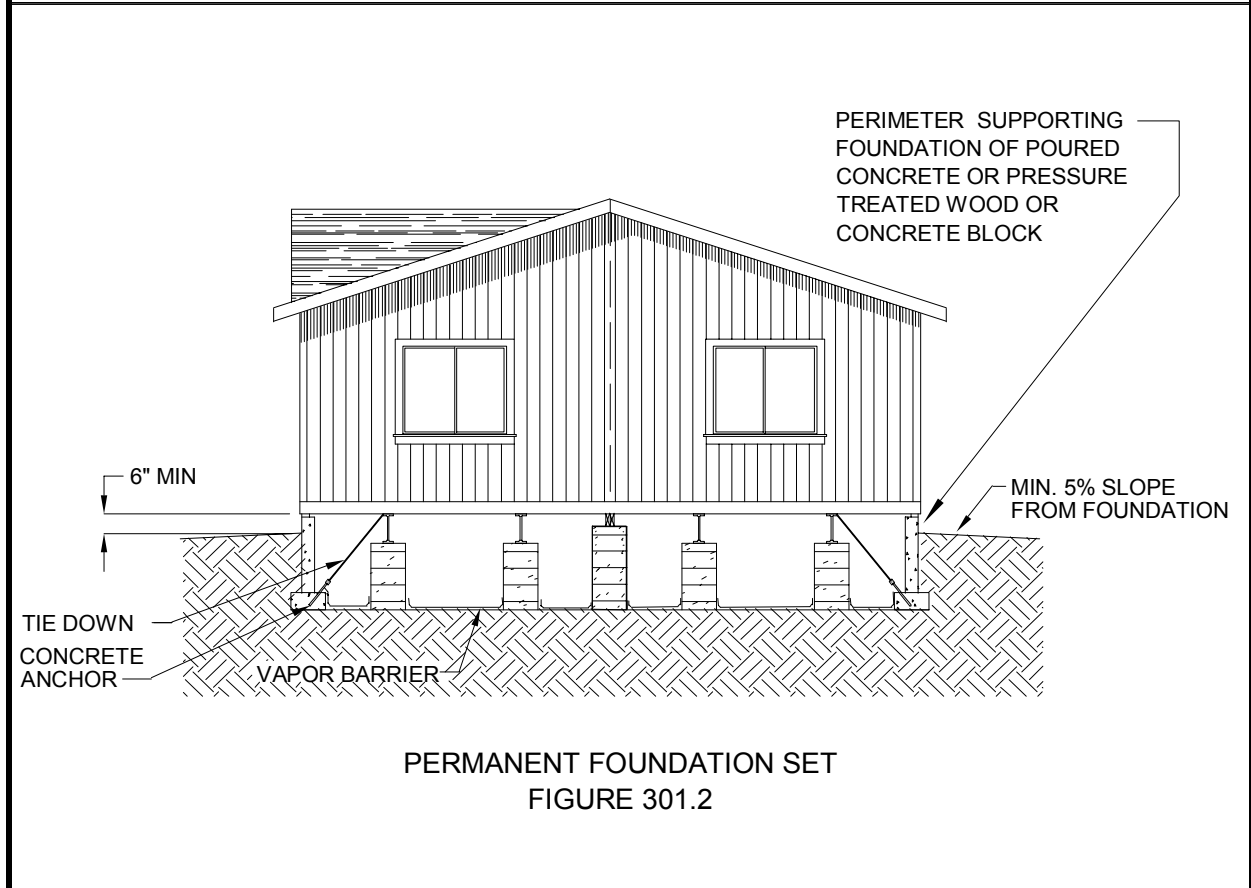
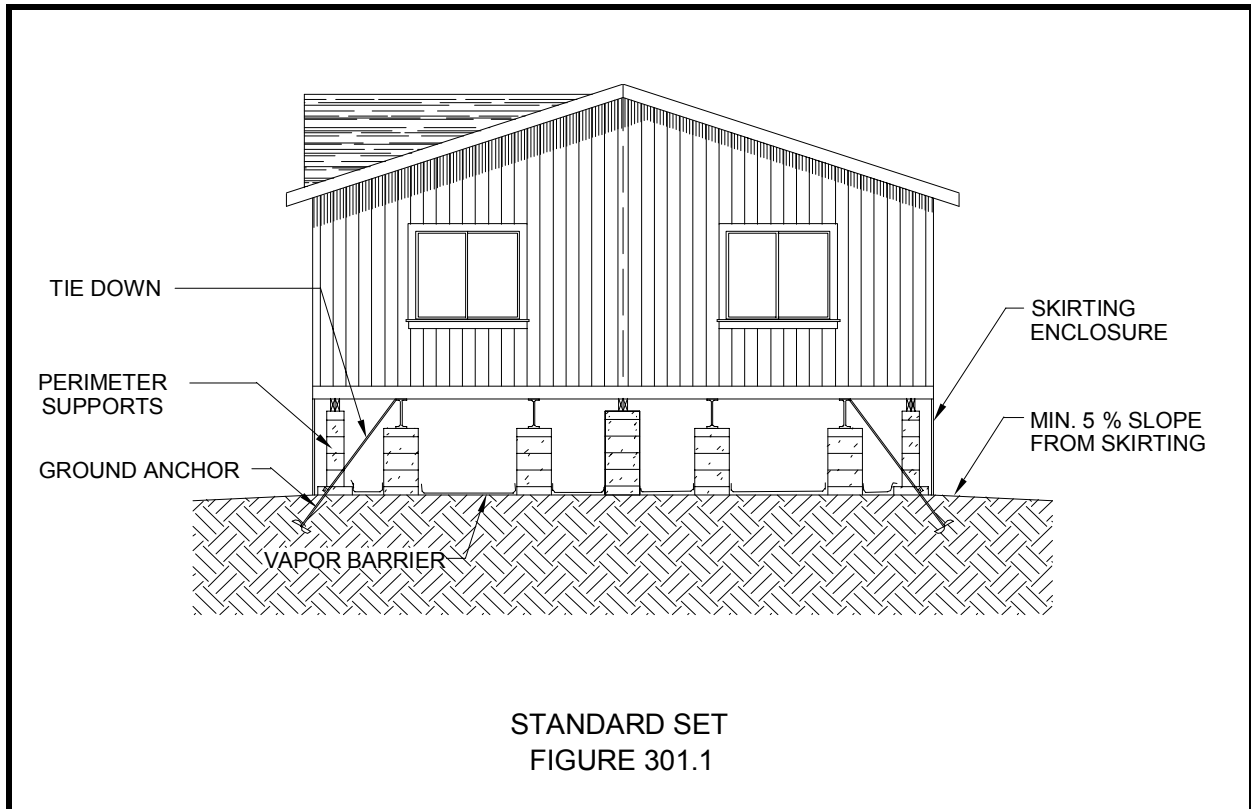

Letter, and those items specifically identified in a Division interpretation.

05. Manufacturer's Installation Instructions. If the manufacturer's installation instructions have been used for any portion of the installation, as permitted by **Subsection 301.04**, a copy of those instructions shall be provided to the inspecting jurisdiction.

06. Unusual Installations. A person is allowed to design for unusual installations not provided for in this standard or in the manufacturer's installation instructions. However, prior written approval must be granted by the authority having jurisdiction. The jurisdiction may require an approved design by an Idaho Licensed Professional engineer.

07. Basic Requirement. Regardless of the type of installation system provided, it shall assure that the manufactured home has adequate support, a substantially level floor, and a flush floor connection at the marriage lines of multi-section manufactured homes.

08. Chassis Removal. Except for wheels, tires, axles, hitches, and transportation lights, no portion of a manufactured home chassis shall be removed before or after the manufactured home is installed. The chassis can be altered only according to the manufacturer's written instructions.

09. Underfloor Ventilation. Underfloor areas of all manufactured homes shall be enclosed and ventilated according to **Sections 702 and 703** of this standard.

10. Separation From Ground. After installation and final grading of the site, the bottom edge of the exterior wall of the manufactured home must be at least six inches (6") above ground level and at least two inches (2") above any other surface where water might collect. The main frames shall be a minimum of

twelve inches (12") from the top of the pier support pad.

11. Close Up. Multi-section manufactured homes shall be sealed at the marriage lines to resist the elements. Wall and roof close up shall be made with similar materials and installed according to the material manufacturer's installation instructions. Shipping fasteners shall be removed from the roof and the roof sealed.

12. Compliance. A manufactured home shall not be installed in a manner which takes the manufactured home out of compliance with state or federal manufactured home construction and safety standards.

13. Approval. Installations shall not be approved until all applicable provisions of this standard have been met, including but not limited to, site preparation, support system, structural connections, tie-down requirements, access and egress requirements, underfloor enclosures with ventilation and access, and all utility connections and crossovers.

14. Temporary Placement. When a manufactured home is placed temporarily in storage by a manufacturer, dealer, or distributor in excess of thirty (30) days, the owner shall assure the manufactured home is adequately supported at each corner and under each main frame beam by a minimum of four supports located within two feet (2') from each end and within eight feet (8') of the front and rear axle. The home shall be sealed to resist exposing the interior of the manufactured home to the elements of weather. When the home is to be set up in excess of 30 days for display, the owner shall assure the home is adequately supported by a minimum of main frame supports located within two feet (2') of each end and spaced a maximum of eight feet (8') on center. The perimeter shall be blocked at all doors and windows over forty-eight inches (48") wide, and at each corner. The marriage

line shall be supported at each ridge beam column, and sealed against the weather.

302. SITE PREPARATION.

01. **Suitability of Site.** Each site shall be suitable for its intended use and acceptable to the authority having jurisdiction based on this standard and local land use regulations. No person shall install a manufactured home on a site which is not in compliance with this Chapter.

02. **Unforeseen Factors.** When unforeseen factors are encountered (e.g., rock formation, high ground water levels, springs), corrective work shall be completed prior to installing the manufactured home.

03. **Grading.** Site grading and drainage shall provide:

- a. Diversion of any surface water away from the manufactured home and accessory structures.
- b. Sufficient site drainage to prevent standing water and soil saturation from becoming detrimental to structures and use of the site.
- c. Finished grade away from the home's foundation or skirting at a minimum slope of five percent (5%) horizontally. **See Figures 301.1 and 301.2.**
- d. Uncovered slabs, patios, or walks shall slope away from the home and structures in order to drain water away from the home and structures.

04. **Erosion.** Where erosion due to high runoff velocity threatens the manufactured home site, adequate grading, landscaping, or drainage systems shall be provided to protect the site from degradation.

05. **Site.** Manufactured home sites shall be natural undisturbed soils or controlled fills and shall be free of grass and other organic

material. All fill shall be engineered, compacted, and tested.

06. **Vapor Retarder.** The ground within the enclosed crawl space beneath every manufactured home shall be covered with a six one-thousandths inch (.006") thick continuous black membrane sheeting vapor retarder installed according to the following requirements.

- a. Membrane sheeting seams shall be overlapped by at least eight inches (8").
- b. Edges of the membrane sheeting shall not extend beyond the perimeter of the manufactured home.
- c. All holes, tears, and penetrations in the membrane sheeting shall be adequately sealed or patched with durable tape.
- d. Underfloor membrane sheeting shall not be in contact with wood unless the wood is pressure treated lumber.
- e. Black polyethylene membrane sheeting shall be installed over the ground. Clear sheeting may be installed under gravel or concrete.
- f. When the manufactured home has a recessed entry, porch, or deck, and the floor in the recessed area is constructed of open decking, the membrane sheeting shall not be installed below the open decking floor.

303. APPROVED INSTALLATION MATERIALS AND COMPONENTS

01. **Component and Materials Specifications.** All installation components shall be designed for their intended use and shall comply with the following:

- a. **Concrete Products.** All precast concrete pads, blocks, caps, and shims shall be equivalent to, or exceed, ASTM C-90-96 and constructed to be lightweight

with a blend of aggregates that conform to ASTM C-33 and ASTM C-331. Pumice and cinder block components shall not be used.

b. **Poured Concrete.** All poured in place concrete shall cure at least four days prior to the installation of the manufactured home and shall have a compressive strength of not less than two thousand five hundred pounds per square inch (2,500 psi) in twenty-eight (28) days.

c. **Wood Products.** All pressure treated wood shall be treated with preservative according to AWWA C22 and shall be identified as to conformance with such standard by an approved agency. Field treatment of cut ends of pressure treated wood is not allowed by this standard.

d. **Wood-Polymer Composite Products.** All wood-polymer composites shall comply with ASTM 790, ASTM 1037, ASTM D-1413, and AWWA E172.

02. **Testing.** All components of the support system shall be tested to their dead load plus superimposed live load equal to three times the required live load using the test procedures in 24 CFR 3280.401.

304. MARRIAGE LINE CONNECTIONS.

01. **General.** After all shipping and close-up material is removed, all sections of multi-section manufactured homes shall be secured to immobilize each section, allow for the transfer of required loads, and protect interior and enclosed spaces.

02. **Shimming.** Gaps from one-half inch (1/2") to one inch (1") between manufactured home sections shall be shimmed and sealed according to **Subsection 304.07**. Gaps greater than one inch (1") shall be corrected by the manufacturer. In no case shall the installer attempt to close gaps by tensioning the lag

bolts while joining the sections together. This procedure will destroy the truss and floor integrity.

03. **Ridge Beam Connections.** Ridge beams of multi-section manufactured homes shall be secured together either:

a. With three-eighths inch (3/8") diameter lag bolts with full penetration, with washers, and spaced equally along the length of the ridge beam at a maximum of twenty-four inches (24") on center and no more than forty-five (45) degrees from perpendicular. Lag bolts will be installed on both sides of the beam, offset approximately one-half of the spacing from each other. **See Figure 304.1**. All ridge beam lag bolts shall be installed in an area where there is solid ridge beam material between the manufactured home sections. Ridge beams shall be predrilled for lag bolts; or

b. With a connection system other than lag bolts which may be engineered by the manufacturer who shall supply the dealer and installer with complete installation instructions. Those instructions shall be in the manufactured home and the ridge beams shall be tagged to indicate an alternate system is required.

04. **Floor Connections.** Floors of multi-section manufactured homes shall be secured together. **See Figures 304.2 and 304.3**.

a. With three-eighths inch (3/8") diameter lag bolts with washers installed diagonally at forty-five (45) degrees or less through each section's rim joists installed in pairs or staggered, but not exceeding a maximum spacing of twenty-four inches (24") on center; or

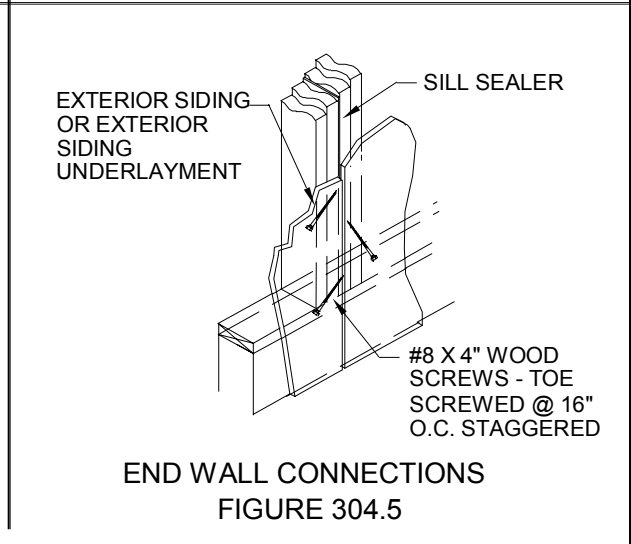
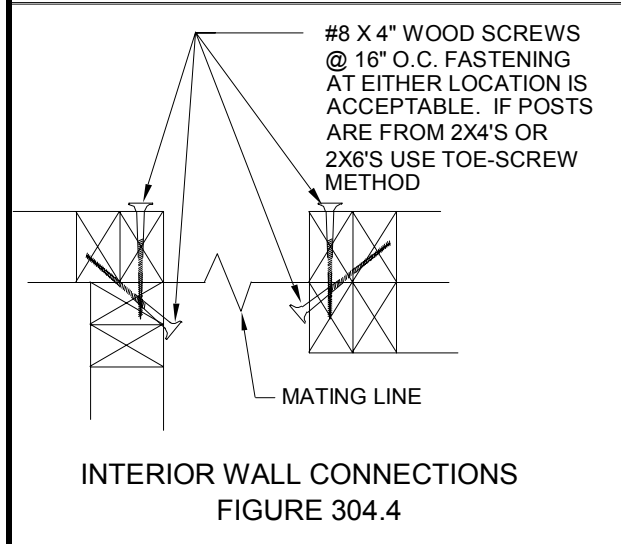
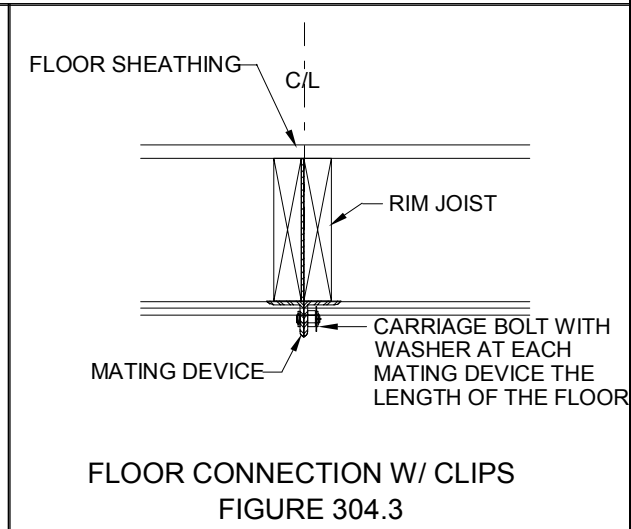
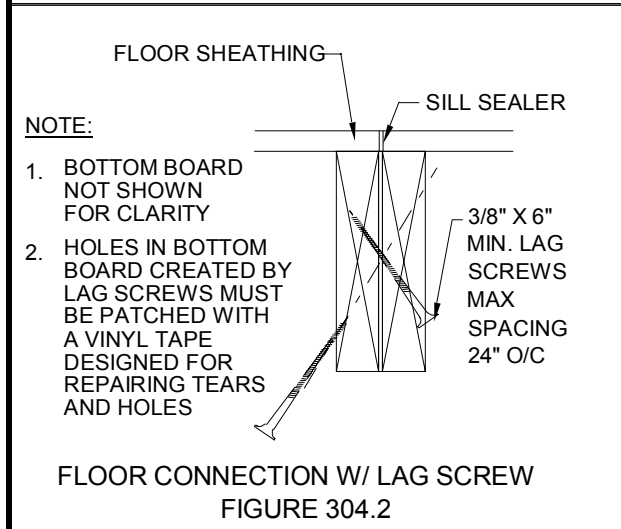
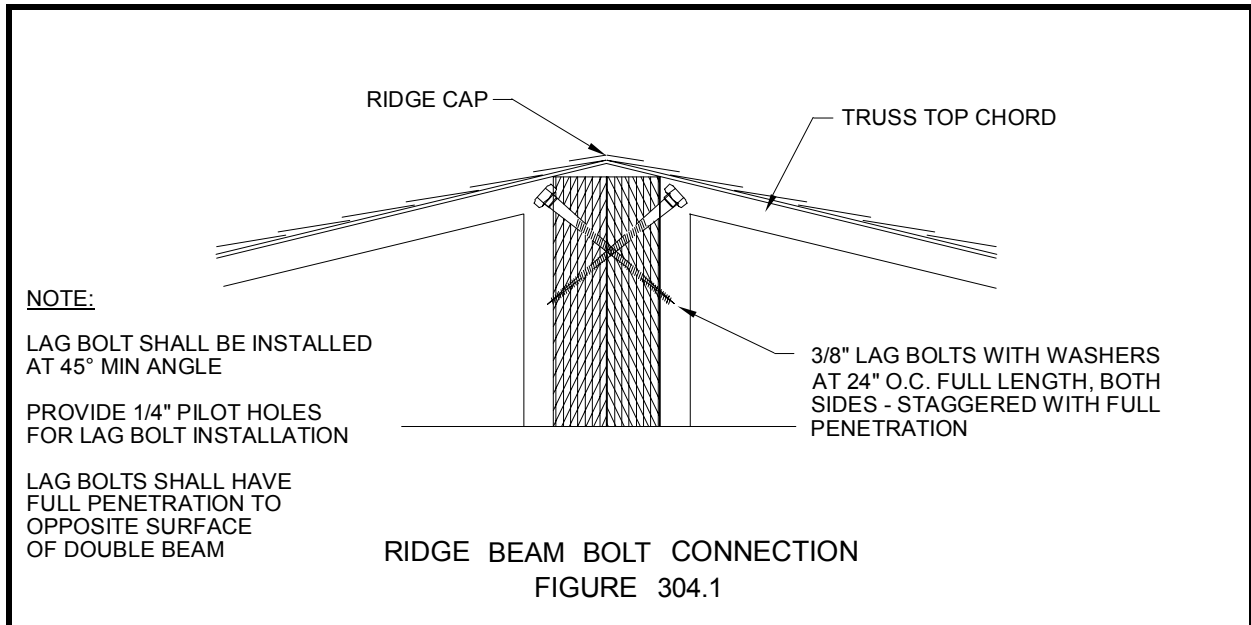

b. With the manufacturer's installed mating devices bolted together with appropriately sized bolts and washers.

05. End Wall and Interior Wall Connections. All end wall studs and interior wall column supports shall be screwed together with four inch (4") long Number Eight (#8) screws spaced sixteen inches (16") on center. **See Figures 304.4 and 304.5.**

06. Lag bolts. Whenever lag bolts are used one-quarter inch (1/4") pilot holes shall first be drilled. The bolts shall be installed so as to provide full penetration of the lag bolt into both beams or joists.

07. Sealing. During installation, joints between all sections shall be cleaned. Where the gap exceeds one-half inch (1/2") top or bottom it shall be filled with a shim. The joints shall then be sealed with a weather stripping gasket material to limit heat loss and prevent air, moisture and other damaging infiltration. The gasket material shall be durable, non-porous caulking, closed cell foam, urethane, or sill seal. If the manufacturer supplies a sealer, it shall be used by the installer. Caulking, when used, shall fill the gap and be capable of compressing and stretching. Sill seal, if used, shall be a minimum of five and one-half inches (5-1/2") wide and attached with fasteners staggered at six inches (6") on center and compressed to form a tight seal. Any remaining gaps shall be caulked or foamed to complete the seal.

08. Patching. All cuts, holes, or tears in the bottom board or floor insulation including, but not limited, to areas around structural connections and electrical, plumbing, mechanical, and heating equipment penetrations shall be adequately repaired to prevent the entrance of rodents and to limit heat loss. Repairs shall be made with materials and adhesives designed for this use.

305. FLOOD RESISTANCE.

01. Location. Manufactured homes shall not be installed in designated flood ways but may be installed in flood hazard areas according to the minimum requirements of this section.

02. Installation. All manufactured homes installed in designated 100 year flood hazard areas shall be installed according to FEMA guidelines or be placed on permanent perimeter foundations to resist flotation, collapse, or lateral movement during a base flood. Homes installed in Manufactured/Mobile home parks shall be allowed to be installed and anchored in accordance with FEMA guidelines.

03. Elevation. The underside of the floor of all manufactured homes installed in designated 100 year flood hazard areas shall be a minimum of twelve inches (12") above the flood elevation to resist flotation, collapse, or lateral movement

04. Underfloor Enclosures. Notwithstanding the requirements of **Section 703**, manufactured homes installed in designated flood hazard areas shall have the underfloor enclosure foundation vents located within twelve inches (12") vertically of the finished grade.

NOTE: The following information on FEMA is not adopted as part of this standard but referenced in this standard for the convenience of the user.

Federal Emergency Management Agency (FEMA). In addition to the state's minimum standards for elevating manufactured homes in flood hazard areas, 44 CFR, Chapter 1, Section 60.3(c) (6) (iv) of the Federal Emergency Management Agency (FEMA) regulations, requires all manufactured homes in designated flood areas to be elevated to resist flotation, collapse, and lateral movement during the base flood. For additional up-to-date information of

FEMA requirements, programs, or insurance contact:

- a. State Coordinator
Dept. Of Water Resources
1301 N. Orchard
Boise, Idaho 83706
- b. Federal Emergency Mgmt Agency
Federal Regional Center
130-228th St. SW
Bothell, Washington 98021-9796

a. Each egress door on a manufactured home shall be accessible by stairs, a ramp, or a deck.

b. Windows and doors shall be adjusted, secured in place, and made operational to provide security, egress, and to minimize air leakage and water penetration.

c. Damage to windows and doors which affect their safety features, thermal performance, or operation shall be repaired or replaced.

d. Each manufactured home shall have an underfloor access provided and constructed according to **Section 704**.

306. EGRESS REQUIREMENTS.

01. **Egress.** Upon completion of installation, and prior to occupancy, each manufactured home shall conform with the following requirements:

02. **Inspection Approval.** Installations shall not be approved until a means of access has

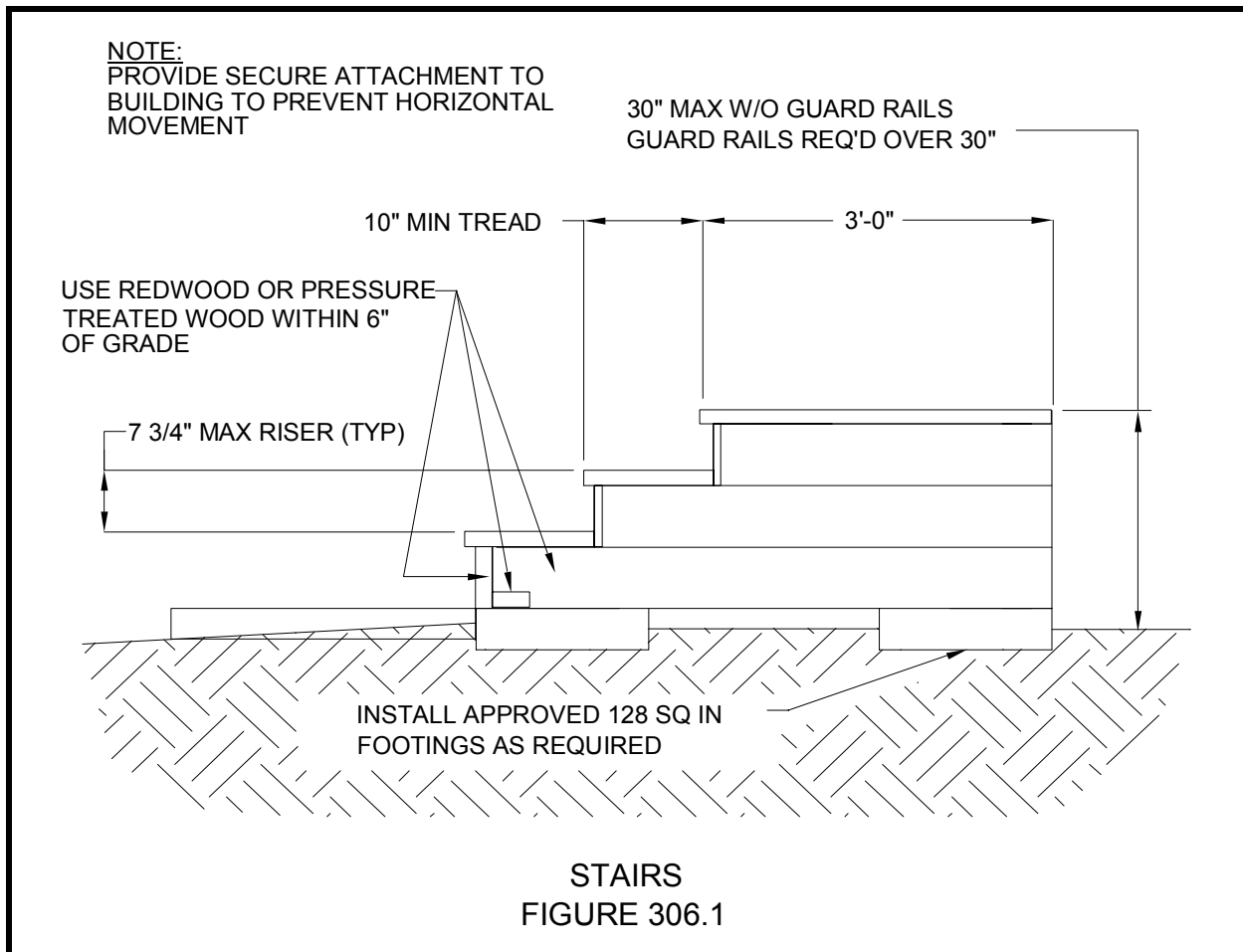

been provided to each of the two required exit doors on the manufactured home.

307. -- 399. RESERVED.

03. **Stairs.** Prior to occupancy, stairs which meet or exceed the following standard, shall be provided at each egress door. See **Figure 306.1** Minimum standards are prescribed in the following Subsections.

a. Stairs shall be constructed with a minimum thirty-six inch (36") width, seven and three-quarters inch ($7\frac{3}{4}$ ") maximum tread rise, minimum ten inch (10") tread run, and a minimum thirty-six inch by thirty-six inch (36" x 36") top landing located not more than seven and three-quarters inch ($7\frac{3}{4}$ ") below the floor of the home. All stairways with four or more risers shall be equipped with a guardrail on at least one side with the top located between thirty-four inches (34") and thirty-eight inches (38") above landings and the nosing of treads. Any stairway with a landing greater than thirty inches (30") above grade must have guard rails constructed in accordance with Section 710.

b. Stairs shall be constructed and cross braced with Number 2 (#2) or better grade lumber. All lumber within six inches (6") of grade shall be redwood or pressure treated.

c. Stairs shall be supported on a minimum of four (4) one hundred twenty-eight (128) square inch footings as described in **Subsection 402.01** of this standard. The two (2) footings closest to the home may be eliminated if the step is securely attached to the home.

04. **Permanent Construction Requirements.** All permanent ramps, steps, stairways, railings, decks, porches, and landings shall be constructed and installed according to **Section 910**.

This page intentionally blank

Chapter 4 STANDARD SET INSTALLATION STANDARDS

401. GENERAL.

This Chapter prescribes the installation requirements that specifically apply to standard set homes. See **Figure 301.1**.

01. **Content:** This series of sections prescribes requirements for:

- a. The support pier system for standard set manufactured homes; and
- b. Tie down anchoring;

02. **Frost Line.** Manufactured homes on a standard set are not required to have support footings below the frost line. However, perimeter blocking must be installed in a manner, and skirting or other approved fascia material must be installed, to minimize the effects of frost.

402. APPROVED INSTALLATION MATERIALS AND COMPONENTS.

01. **Footings.** Pier support footings shall be a minimum of two hundred fifty-six (256) square inches and not less than the width of the pier being supported. Ridge beam column support footings shall be sized according to **Subsection 403.03.b**. Footings shall be any one of the following, except where specifically stated otherwise.

- a. **Precast Pads.** One (1) or more precast concrete pads with a nominal size of sixteen inches by sixteen inches (16" x 16") by four inches (4") thick or two (2) or more pads with a nominal size of eight inches by sixteen inches (8" x 16") by four inches (4") thick. Eight inch by sixteen inch (8" x 16") pads may be used only with concrete block piers. The pier blocks shall

be perpendicular to the joint of the pad. See **Figure 402.1**.

- b. **Poured Concrete Pads.** Nominal four inch (4") or thicker poured-in-place individual concrete pads, either square or round. See **Figure 402.2**.

- c. **Lumber or Polymer Stacked Pads.** Pads of two (2) to four (4) layers of two inch (2") nominal size thick foundation grade lumber, pressure treated on all six sides, or pads of two to four layers of two inch (2") nominal size thick polymer composite. Each layer shall be laid perpendicular to the layer below it. See **Figure 402.3**.

- d. **Lumber Pads.** Pads of one layer of two inch (2") nominal size thick foundation grade lumber pressure treated on all six sides. If used with concrete piers, the grain shall be parallel with the long side of the block with no more than one inch (1") of wood exposed beyond the long sides of the block. See **Figure 402.4**.

- e. **Plywood Pads.** Pads of one (1) piece of one and one-quarter inch (1-1/4") thick plywood pressure treated on all six sides or pads of two stacked pieces of three-quarter inch (3/4") thick plywood pressure treated on all six sides. See **Figure 402.5**.

- f. **Runners.** Continuous concrete runners with a thickness of six inches (6") and not less than eighteen inches (18") wide [twenty inches (20") wide under the marriage line] with two (2) continuous three-eighths inch diameter (#3) reinforcing bars. The reinforcing bars shall be centered vertically in the runner, ten inches (10") apart and shall not be closer

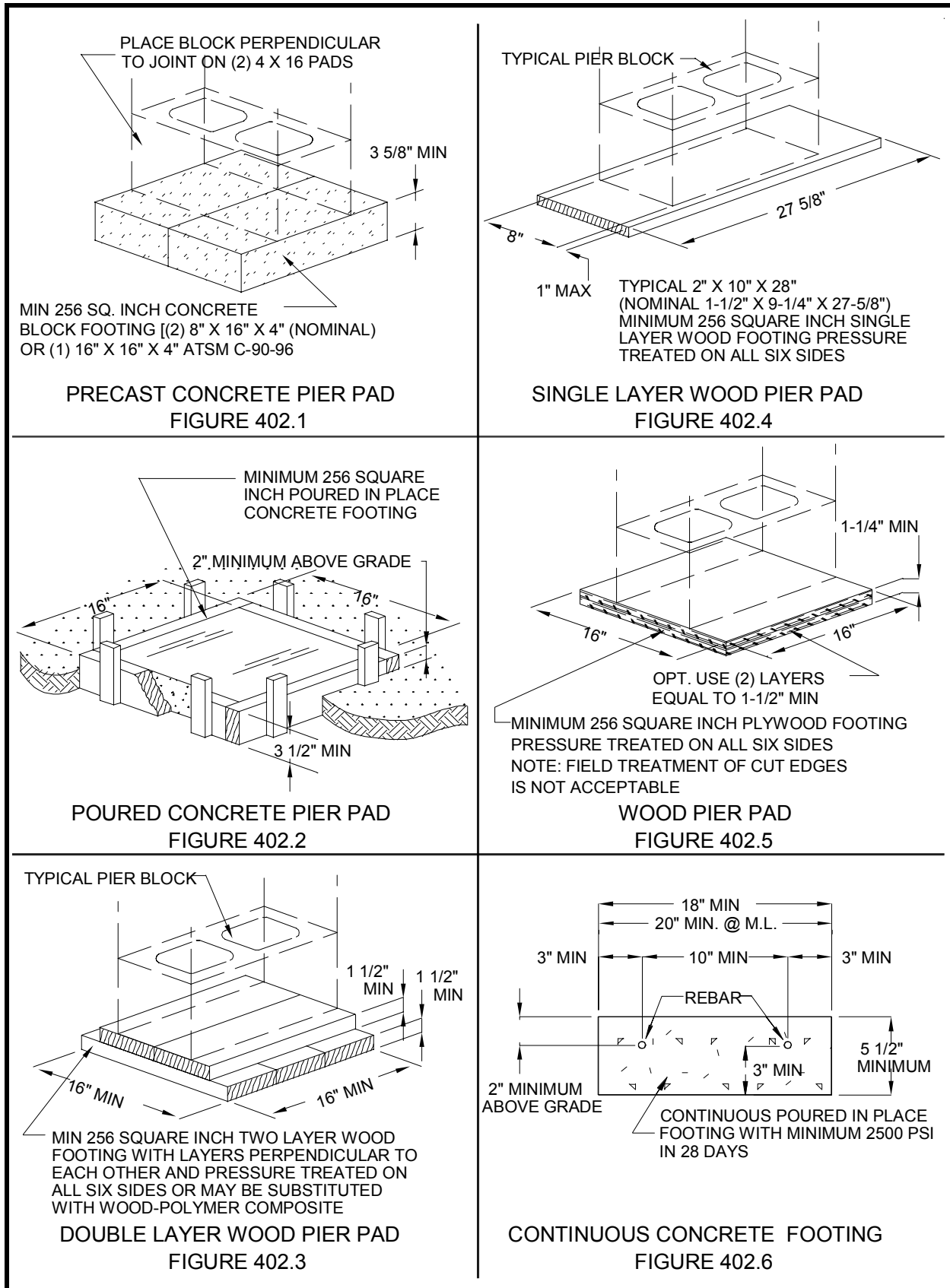

than three inches (3") from the edge. The runner shall be centered beneath the mainframe. See **Figure 402.6**. These runners may be poured wide enough to include the outer mainframe and perimeter supports, or the inner mainframes and marriage line supports, on the same runner. If runners are poured wide enough to include two or more rows of supports two (2) continuous three-eighths inch diameter (#3) reinforcing bars shall be used for each row of supports. The reinforcing bars shall be centered vertically in the runner, spaced equidistant apart, and shall not be closer than three inches (3") nor farther than six inches (6") from the edge.

g. **Other.** Listed prefabricated pads or other equivalent materials approved by the Division and the Manufactured Home Installation Committee.

02. **Block Piers.** Concrete block piers shall be placed on approved minimum two hundred fifty-six (256) square inch (or sized as required for ridge beam column supports) footings and shall not exceed the size of the footing. Block piers shall be capped and shimmed with approved components. Piers shall be:

a. **Concrete block.** The blocks shall be either open or closed cell precast lightweight concrete of nominal size of eight inches by eight inches by sixteen inches (8" x 8" x 16"). Open cell blocks shall be positioned vertically. See **Figure 402.7**. Cinder or pumice blocks shall not be used.

(1) **Single Stack.** Block piers up to thirty-six inches (36") high under the main frame or marriage line and forty-eight inches (48") high under the perimeter walls may be single stacked. Single stacked block piers shall be placed perpendicular to the main frame and marriage line and parallel at the

perimeter wall. Single stack piers shall be placed perpendicular to the joint of two (2) eight inch by sixteen inch (8" x 16") nominal size concrete pads. See **Figure 402.1**.

(2) **Double Stack.** Block piers over thirty-six inches (36") high under the main frame and marriage line, and over forty-eight inches (48") high under the perimeter walls, shall be double stacked with blocks interlocking. See **Figure 402.8**.

(3) **Maximum Height.** No concrete block piers shall be constructed over eighty inches (80") in height unless designed by an Idaho Licensed Professional engineer.

(4) **Capacity.** Single stack block piers shall be used for loads not to exceed five thousand (5,000) pounds. Double stack block piers shall be used for loads not to exceed sixteen thousand (16,000) pounds. Double and single piers may be combined for higher loads.

03. **Block Pier Caps.** Each block pier shall be capped with a pier cap equal in area to the pier blocking (i.e., 8" x 16" or 16" x 16"). See **Figures 402.7, 402.8, and 402.9**. Pier caps shall be one or more of the following.

a. **Precast Block.** A solid concrete block with a nominal thickness of four inches (4").

b. **Plywood.** One (1) piece of one and one-quarter inch (1-1/4") thick plywood, or two (2) pieces of three-quarter inch (3/4") thick plywood.

c. **Lumber.** One (1) two inch (2") nominally thick Number 2 (#2) or better grade lumber.

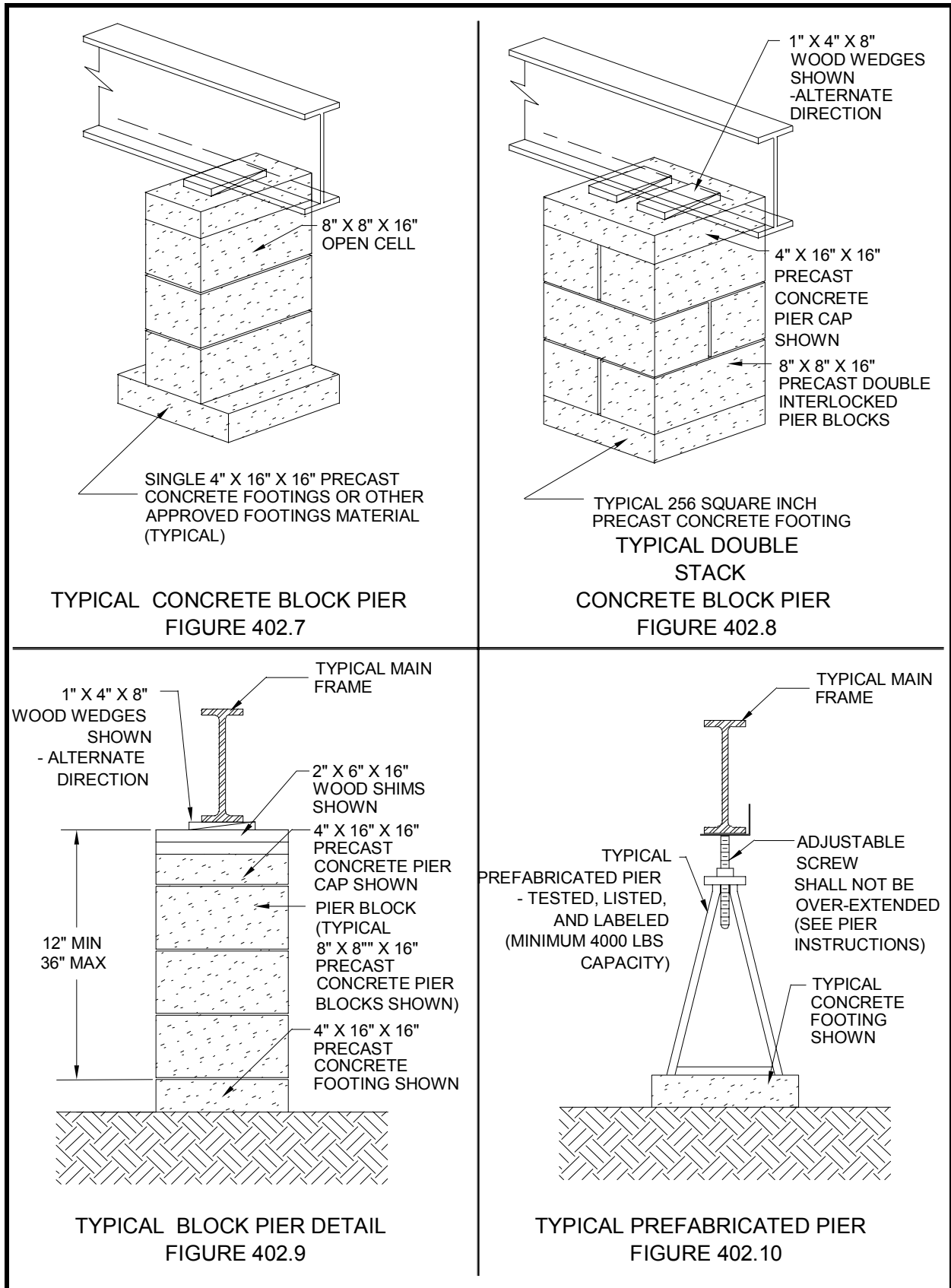

- d. **Polymer.** One (1) two inch (2") nominally thick wood polymer composite.
- e. **Other.** Listed or equivalent materials approved by the Division and the Manufactured Home Installation Committee.
04. **Block Pier Shims.** Where shim material is used between the top of the pier cap and the bottom of the main frame, the shimming material shall not exceed five inches (5") vertically. See **Figure 402.9**. Pier shims, when used, shall be one or more of the following:
- a. **Precast Concrete.** Two inch (2") thick solid concrete blocks equal in area to the pier cap;
- b. **Plywood.** Three-quarter inch (3/4") or thicker plywood equal in area to the pier cap;
- c. **Lumber.** Two inch (2") nominally thick Number Two (#2) or better grade lumber not less than five and one-half inches (5-1/2") in width and sixteen inches (16") long;
- d. **Polymer.** One and one-quarter inch (1-1/4") minimum thickness wood polymer not less than five and one-half inches (5-1/2") in width and sixteen inches (16") long; or
- e. **Other.** Listed or equivalent materials approved by the Division and the Manufactured Home Installation Committee.
05. **Block Pier Wedges.** No more than two sets of wedges three-quarter inch (3/4") thick or one set of wedges one and one-half inches (1-1/2") thick by three and one-half inches (3-1/2") wide by eight inches (8") to sixteen inches (16") long may be used. They must be fitted perpendicular with, and driven tight to, the bottom of the main frame or floor to transfer loads uniformly to the pier. See **Figures 402.8 and 402.9**.
06. **Prefabricated Piers.** Prefabricated piers shall be placed on approved footings and shall not exceed the size of the footing. See **Figure 402.10**. Piers shall be:
- a. **Tested and Listed.** All prefabricated piers shall be tested, listed, and labeled for a capacity of not less than four thousand (4,000) pounds. See **Subsection 303.02**.
- b. **Instructions.** The installation of the piers shall be in compliance with pier manufacturers' instructions which shall be left with the home.
- c. **Shims.** No shims shall be used with a prefabricated pier.
- d. **Adjustable Heads.** All piers shall be of the type fitted with an adjustable head and nut. The adjustment shall not exceed that permitted by the manufacturer's instructions.
07. **Other piers.** Other piers may be used only by approval of the Division of Building Safety and the Manufactured Home Installation Committee.
- 403. INSTALLATION SUPPORT REQUIREMENTS.**
01. **Main Frame Supports.** The main frame of all standard set manufactured home installations shall be supported as prescribed in the following Subsections. See **Figure 403.1**. All materials and components shall comply with the requirements of **Section 402**.
- a. **Footings for Standard Sets.** The footings for the support piers under the main frames of a standard set manufactured home shall be any of the footings in **Subsection 402.01**. The minimum size shall be two hundred fifty-six (256) square inches.

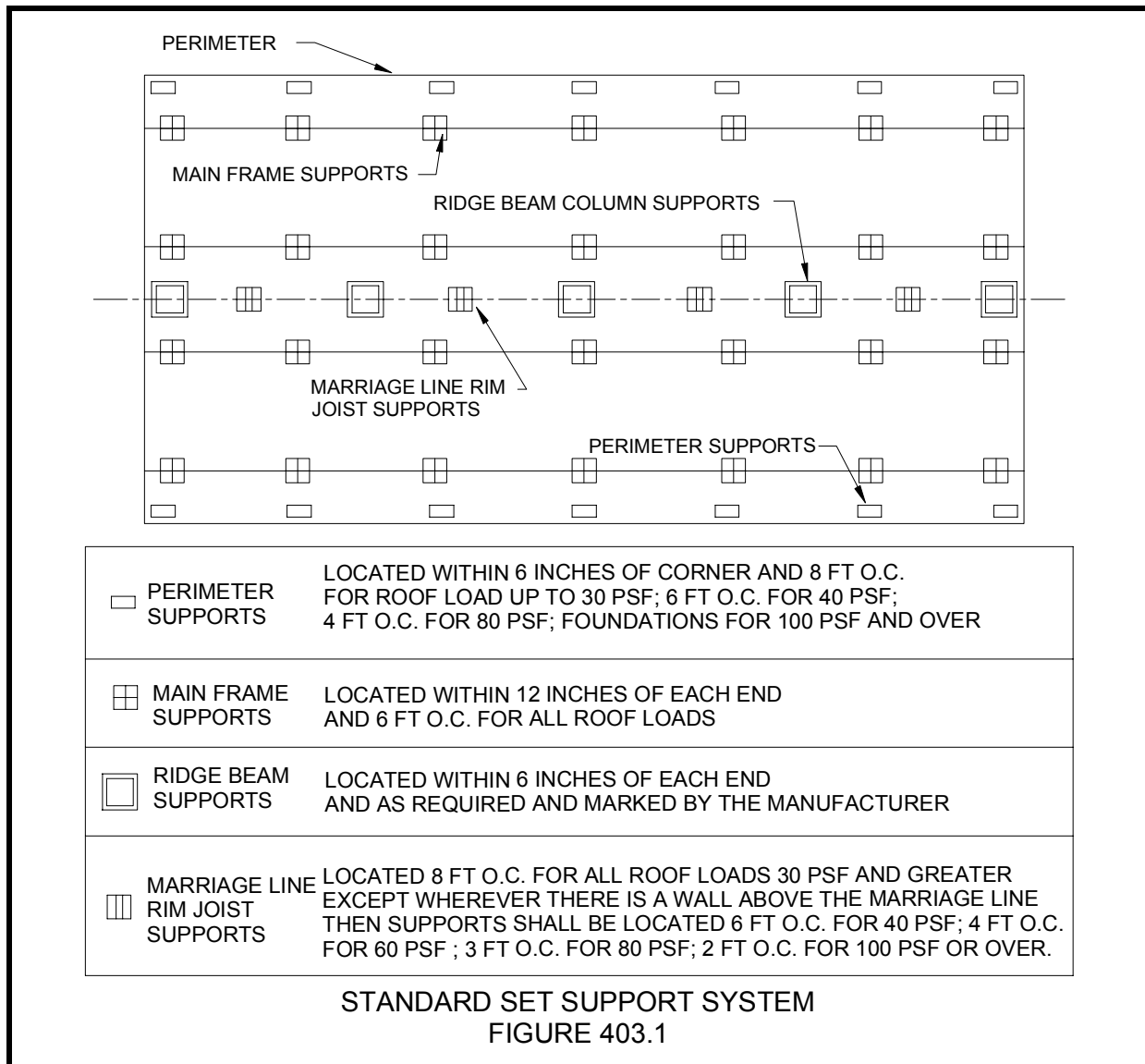

c. **Piers.** The piers for the support of main frames in standard sets shall be any of the piers in **Subsections 402.02, 402.06, or 402.07**. When block piers are used they shall be placed perpendicular to the main frame.

d. **Location of Supports.** The footings and pier stands under the main frame shall be placed not more than twelve inches (12") from the ends of the frames. The footings and pier stands shall continue to be set six feet (6') on center the full length of the frame. A six inch (6") variance is

allowable to clear obstructions. This spacing shall be maintained in all roof loads up to and including one hundred twenty pounds per square foot (120 psf).

02. **Perimeter Supports.** The perimeter side walls of all manufactured homes over eleven feet (11') in width shall be supported as prescribed in the following Subsections. See **Figure 403.1**. All materials and components shall comply with the requirements of **Section 402**.

c. **Piers.** The piers for the support of main frames in standard sets shall be any of the piers in **Subsections 402.02, 402.06, or 402.07.** When block piers are used they shall be placed perpendicular to the main frame.

d. **Location of Supports.** The footings and pier stands under the main frame shall be placed not more than twelve inches (12") from the ends of the frames. The footings and pier stands shall continue to be set six feet (6') on center the full length of the frame. A six inch (6") variance is allowable to clear obstructions. This spacing shall be maintained in all roof loads up to and including one hundred twenty pounds per square foot (120 psf).

02. **Perimeter Supports.** The perimeter side walls of all manufactured homes over eleven feet (11') in width shall be supported as prescribed in the following Subsections. **See Figure 403.1.** All materials and components shall comply with the requirements of **Section 402.**

a. **Perimeter Footings for Standard Sets.** The footings for the support piers under the perimeter side walls of a standard set manufactured home shall be any of the footings in **Subsection 402.01.** The minimum footing size shall be two hundred fifty-six (256) square inches. Footings shall not extend beyond the exterior perimeter walls of the manufactured home.

b. **Perimeter Piers for Standard Sets.** The piers for the support under the perimeter side walls of a standard set manufactured home shall be any of the piers in **Subsections 402.02, 402.06, or 402.07.**

(1) All piers must be installed on approved footings which meet the requirements of **Subsection 402.01.**

(2) Block piers are required if the footing is constructed of eight inch by sixteen inch by four inch (8" x 16" x 4") precast pads. The pier blocks must be placed perpendicular to the joint of the pads. **See Figure 402.1.**

(3) When it is not possible to install a perimeter pier directly under the exterior sidewall, the floor shall be supported by a four inch (4") wide by six inch (6") high nominal size or equal horizontal Number Two (#2) or better grade wood beam, spanning a minimum of three floor joists and supported by an approved pier recessed not more than ten inches (10") from the perimeter. **See Figures 403.2 and 403.3.** When wood wedges are used with the beams, they shall be installed at each end of the block pier between the top of the pier and the bottom of the beam. Block piers shall be placed perpendicular to the floor joists.

(i) **Exception:** In homes with longitudinal joists and where the third joist is above or inside the main frame beam, the pier support beam shall span a minimum of two joists.

(4) Where a manufactured home has cantilevered portions and expanded rooms, these protrusions shall be supported by piers at each corner and along the cantilevered portion of the sidewall perimeter.

c. **Location of Supports.** Footings and pier stands under the perimeter side walls shall be located as prescribed below.

(1) Six inches (6") or less from each corner.

NOTE:
WHEN WOOD WEDGES ARE USED WITH WOOD SUPPORT BEAMS THEY SHALL BE INSTALLED AT EACH END BETWEEN THE TOP OF THE PIER SHIM AND THE BOTTOM OF THE HORIZONTAL BEAM

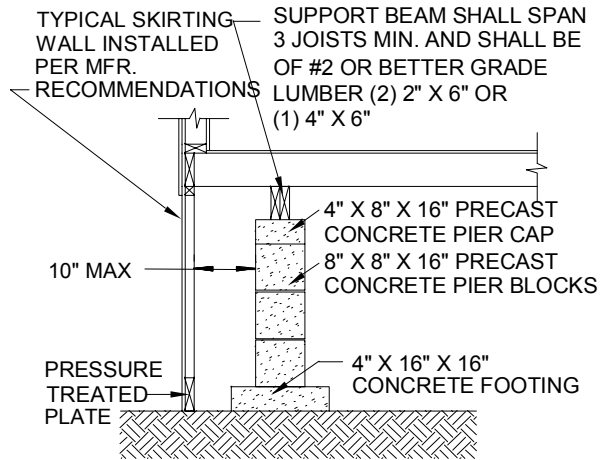

PERIMETER PIER
W/ TRANSVERSE JOISTS
FIGURE 403.2

NOTE:
WHEN WOOD WEDGES ARE USED WITH WOOD SUPPORT BEAMS THEY SHALL BE INSTALLED AT EACH END BETWEEN THE TOP OF THE PIER SHIM AND THE BOTTOM OF THE HORIZONTAL BEAM

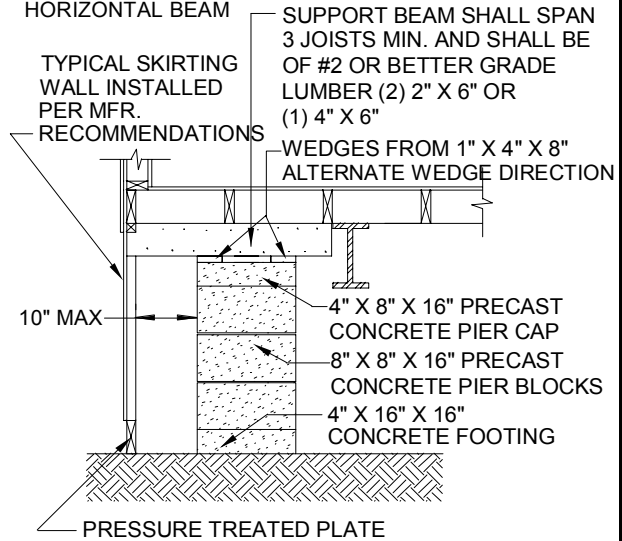

PERIMETER PIER
W/ LONGITUDINAL JOISTS
FIGURE 403.3

TYPICAL 4" X 16" X 16" PAD SPANNING PADS BELOW

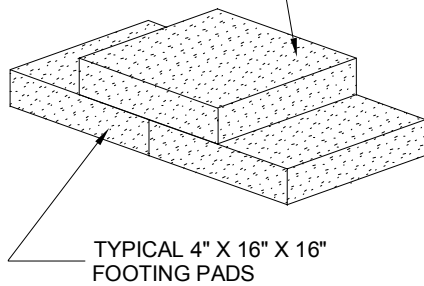

512 SQ IN PIER PAD
(5000 POUND CAPACITY)
FIGURE 403.4

TYPICAL 4" X 16" X 16" PAD SPANNING PADS BELOW

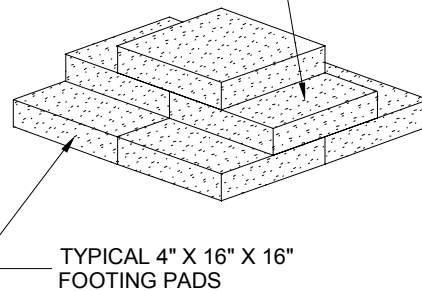

1024 SQ IN PIER PAD
(11,000 POUND CAPACITY)
FIGURE 403.5

(2) Eight feet (8') on center maximum for roof loads from thirty to forty pounds per square foot (30 to 40 psf). Thirty pounds per square foot is the minimum permissible snow load rating in Idaho.

(3) Six feet (6') on center maximum for roof loads over forty and up to sixty pounds per square foot (40 to 60 psf).

(4) Four feet (4') on center maximum for roof loads over sixty and up to eighty pounds per square foot (60 to 80 psf).

(5) For all homes with roof loads over eighty pounds per square foot (80 psf) outside of parks a permanent foundation shall be installed.

(6) A six inch (6") variance is allowable to clear obstructions.

03. Marriage line Supports. The marriage line rim joists and ridge beam columns of all standard set multi-section manufactured homes shall be supported as prescribed in the following Subsections. **See Figure 403.1.** All materials and components shall comply with the requirements of **Section 402.**

a. Marriage Line Rim Joist Supports. The entire marriage line shall be supported by minimum two hundred fifty-six (256) square inch footings and piers. **See Subsections 402.01, 402.02, 402.06, or 402.07.**

b. Ridge Beam Column Supports. Marriage line roof ridge beam column supports shall comply with the requirements prescribed in the following subsections.

(1) The manufacturer shall identify in a diagram the load on, and the location of, each column. The diagram shall be provided to the homeowner, and upon

request, to the dealer, installer, and local authority having jurisdiction.

(2) The manufacturer shall clearly mark the location of each column. These markings shall remain visible for inspection after the installation is completed.

(3) The installer shall use the manufacturer's diagram and markings to determine locations and loads of column supports.

(4) The installer shall use **Table 400-A** to determine the size of footing required for each column load.

(5) Footings for marriage line roof ridge beam support columns shall be constructed according to any one of the following four methods.

(a) Multilayered sixteen inch by sixteen inch by four inch (16" x 16" x 4") precast concrete pads placed in a pyramid shape to distribute the load from the pier to the base. **See Figures 403.4 and 403.5.** Each layer of blocks shall span at least fifty percent (50%) of each block in the layer beneath.

(b) Poured in place concrete pads a minimum of eight inches (8") nominal thickness with two (2) three-eighths inch diameter (#3) reinforcing bars in each direction.

(c) A poured concrete footing runner a minimum of eight inches (8") nominal thickness by twenty inches (20") wide with two properly positioned three-eighths inch (#3) reinforcing bars. **See Subsection 402.01.f.**

Table 400-A

Footing Size (Inches)	Capacity (Pounds)		Footing Size (Inches)	Capacity (Pounds)
15 x 15	2,500		29 x 29	8,500
17 x 17	3,000		30 x 30	9,000
18 x 18	3,500		31 x 31	10,000
20 x 20	4,000		32 x 32	11,000
21 x 21	4,500		34 x 34	12,000
22 x 22	5,000		35 x 35	13,000
23 x 23	5,500		37 x 37	14,000
24 x 24	6,000		38 x 38	15,000
25 x 25	6,500		39 x 39	16,000
26 x 26	7,000		40 x 40	17,000
27 x 27	7,500		42 x 42	18,000
28 x 28	8,000		43 x 43	19,000

The footing sizes shown are for square pads and are based on the area (square inches) required for the load. Other footing configurations, such as a rectangular configuration, may be used, provided the area (square inches) is equal to or greater than the area of the square footing shown in the table. For example, a 12-inch x 22-inch (264-square-inch) footing may be used in place of a 16-inch x 16-inch (256-square-inch) footing. Also, two 12-inch x 24-inch pads may be used in place of one 24-inch x 24-inch pad

(d) Pads of two to four layers of minimum two inch by ten inch (2" x 10") nominal size lumber pressure treated on all six sides. The length of the pad shall not exceed double the width. The boards in each layer shall be laid crosswise to the boards in the layer beneath.

d. **Piers.** Marriage line piers shall be concrete block or listed prefabricated piers. See **Subsections 402.02** and **402.06**. All ridge beam columns with a load in excess of five thousand pounds (5,000 lbs.

shall have multiple blocked concrete piers or prefabricated piers listed and labeled to support the load either by itself or in combination with another pier.

e. **Location of Supports.** Marriage line supports shall be located as prescribed below. See **Figure 403.1**.

(1) On a standard set the first support will be the first ridge beam column support, which shall be within six inches (6") of each end.

(2) Ridge beam column supports shall be sized and located per the diagrams supplied by the manufacturer for each home and **Table 400-A**.

(3) Marriage line rim joist supports shall be located along the entire length of the marriage line as prescribed below.

(a) Eight feet (8') on center maximum for all roof loads thirty pounds per square foot (30 psf) and greater. Thirty pounds per square foot is the minimum permissible snow load rating in Idaho for new manufactured homes.

(b) Six feet (6') on center maximum for roof loads over forty and up to sixty pounds per square foot (40 to 60 psf) wherever there is a wall above the marriage line.

(c) Four feet (4') on center maximum for roof loads over sixty and up to eighty pounds per square foot (60 to 80 psf) wherever there is a wall above the marriage line.

(d) Three feet (3') on center maximum for roof loads over eighty and up to one hundred pounds per square foot (80 to 100 psf) wherever there is a wall above the marriage line.

(e) Two feet (2') on center maximum for roof loads over one hundred pounds per square foot (100 psf) wherever there is a wall above the marriage line.

(f) As an alternate support system to that specified in (d) and (e) above, a marriage line pony wall may be constructed of minimum two inch by six inch (2" x 6") nominal size studs,

twenty-four inches (24") on center, with double top and single (treated) bottom plates to support the marriage line. A four inch by six inch (4" x 6") nominal size post shall be placed in this pony wall at all ridge beam support locations identified by the manufacturer. All wood shall have a structural rating equal to, or greater than, #2 SPF.

(g) Ridge beam column supports may be considered to be rim joist supports as long as the maximum allowable spacing between supports is not exceeded.

04. Height of Installation. No more than twenty-five percent (25%) of the main frame pier supports of a manufactured home shall exceed thirty-six inches (36") in height without prior approval of the local authority having jurisdiction. Pier heights shall be measured from the top of the footing to the bottom of the frame. **See Figure 402.9.** Maximum pier height shall not exceed eighty inches (80"). **See Figure 402.8.**

404. ANCHORING.

01. Anchoring. To resist lateral movement from high winds, earthquakes, and flooding, all manufactured homes shall be anchored down.

02. Loads. Anchoring equipment including all anchors, straps, and tension devices used to secure a manufactured home when installed, shall be capable of resisting an allowable working load at least equal to or exceeding three thousand one hundred-fifty pounds (3,150 lbs) and shall be capable of withstanding fifty percent (50%) overload (4,725 lbs) without failure of either the anchoring equipment or the attachment point to the manufactured home. When the stabilizing system is designed by a qualified Idaho Licensed Engineer, alternate working loads

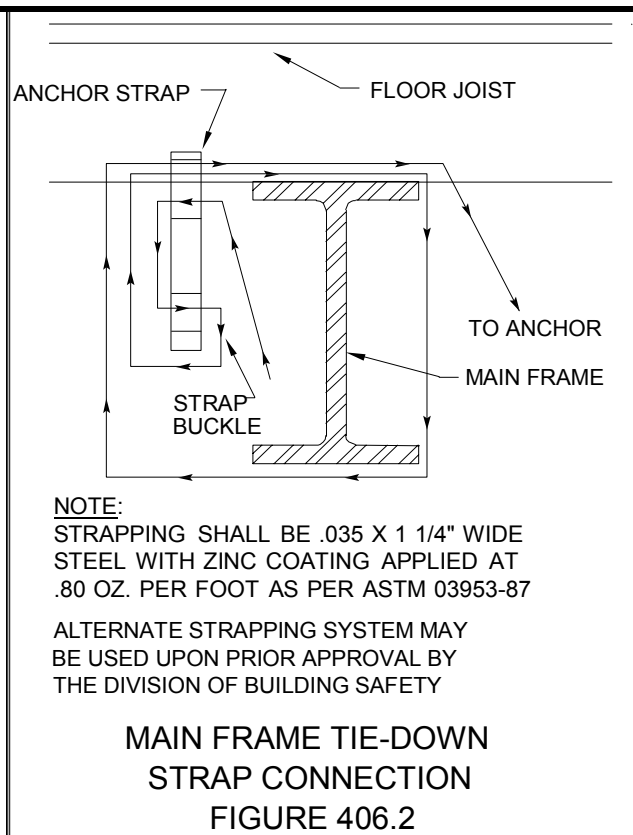
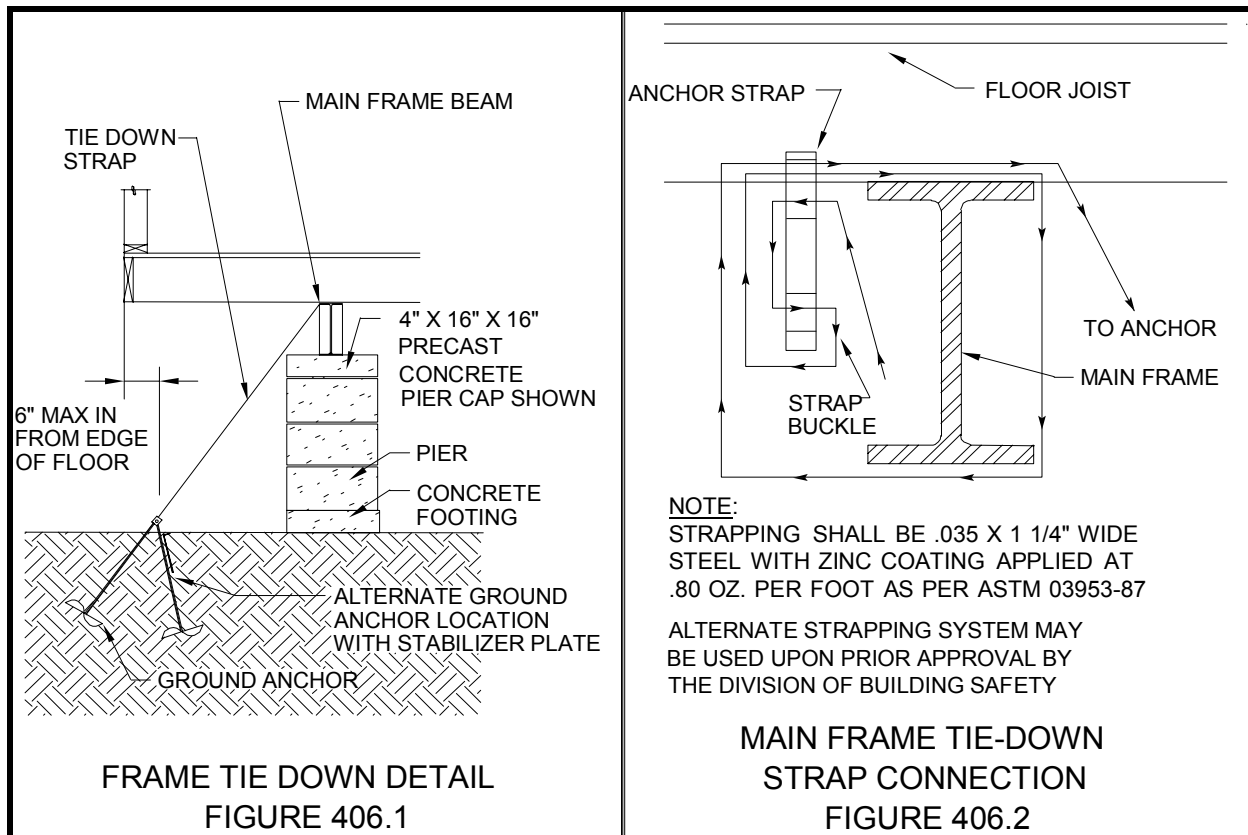

may be used, provided the anchoring equipment is capable of withstanding a fifty percent (50%) overload. Each type of anchor suitable for the purpose of this standard shall meet the following criteria.

- a. Each anchor shall be certified and listed as to its resistance against pulling based on the maximum angle of diagonal or vertical tie loading and the angle of anchor installation and the type of soil in which the anchor is to be installed.
- b. Anchors designed for the connection of multiple ties shall be certified and listed as being capable of resisting the combined working load and overload consistent with the intent expressed herein; and shall be installed to resist resultant forces.
- c. Each anchor shall be selected based on the soil class at the depth where the anchor will be installed.

d. Each anchor shall, at a minimum, be installed to the full depth shown in the anchor manufacturer's installation instructions. The retainer or stabilizer plates shall be installed to achieve the required ground anchor resistance capacity. **See Figure 406.1.**

e. The load carrying portion of the anchor shall extend below the frost line.

03. Installation Instructions. Anchor manufacturers shall provide manufacturer's installation instructions for all listed and approved anchoring systems sold in Idaho. Anchor manufacturer's installation instructions shall be consistent with the product listing and approval. One copy of the anchor manufacturer's instructions must be made available to the inspectors of the local authority having jurisdiction.

a. **Caution:** Before installing ground anchors, the site should be checked for

marked and unmarked underground utilities.

04. **Testing.** Anchoring devices shall be tested to one and one-half (1.5) times the horizontal wind load of fifteen pounds per square foot (15 psf) and a roof uplift of nine pounds per square foot (9 psf) using the test procedures in the current version of ASTM D-3953.

05. **Ties.** All tie strapping shall be fastened to anchors and drawn tight with adjustable tensioning devices supplied with the anchor.

a. Tie strapping shall be certified and listed to be capable of resisting an allowable working load of three thousand one hundred-fifty pounds (3,150 lbs) with no more than two percent (2%) elongation and shall withstand a fifty percent (50%) overload.

b. Ties shall connect the anchor to the main frame I-beams which run lengthwise under the manufactured home. Ties shall not connect to steel outrigger or cross member beams which fasten to, and intersect with, the main frame I-beams.

c. Tie materials shall be designed to prevent self-disconnection when ties are slack. Open hook ends shall not be used in any part of the anchoring system. **See Figure 406.2.**

06. **Spacing.** Unless otherwise specified in the anchoring equipment manufacturer's installation instructions, anchoring devices shall be installed on both sides of the manufactured home with a maximum spacing of eleven feet (11') on center and no more than two feet (2') from each end.

07. **Certification.** Anchoring equipment is certified when tested, listed, and labeled by a nationally recognized testing and listing laboratory, or designed by a Idaho Licensed Professional Engineer and approved by the Division of Building Safety and the Manufactured Home Installation Committee.

08. **Alternate anchoring systems.** Alternate anchoring systems may be used when approved by the Division and the Manufactured Home Installation Committee.

407. -- 499. RESERVED.

This page intentionally blank

Chapter 5
PERMANENT FOUNDATION INSTALLATION STANDARDS

501. GENERAL.

There are two basic types of installations - standard set and permanent foundation set. This Chapter prescribes the installation requirements for homes installed on permanent foundations. See **Figure 301.2**.

01. **Content:** This series of sections prescribes requirements for:

- a. The foundation and support pier system for manufactured homes installed on permanent foundations;
- b. Tie down anchoring;

02. **Frost Line.** Manufactured homes on a permanent foundation shall have the footings below the frost line. The local authority having jurisdiction will prescribe the required depth.

502. APPROVED INSTALLATION MATERIALS AND COMPONENTS.

01. **Footings.** Pier support footings shall be a minimum of two hundred fifty-six (256) square inches and not less than the width of the pier being supported. Ridge beam column support footings shall be sized according to **Subsection 503.03.b**. Footings shall be either one of the following, except where specifically stated otherwise.

a. **Poured Concrete Pads.** Nominal eight inch (8") or thicker poured-in-place individual concrete pads, either square or round. See **Figure 502.1**.

b. **Runners.** Continuous concrete runners with a thickness of eight inches (8") and not less than eighteen inches (18") wide [twenty inches (20") wide under the marriage line] with two (2) continuous three-eighths inch diameter (#3)

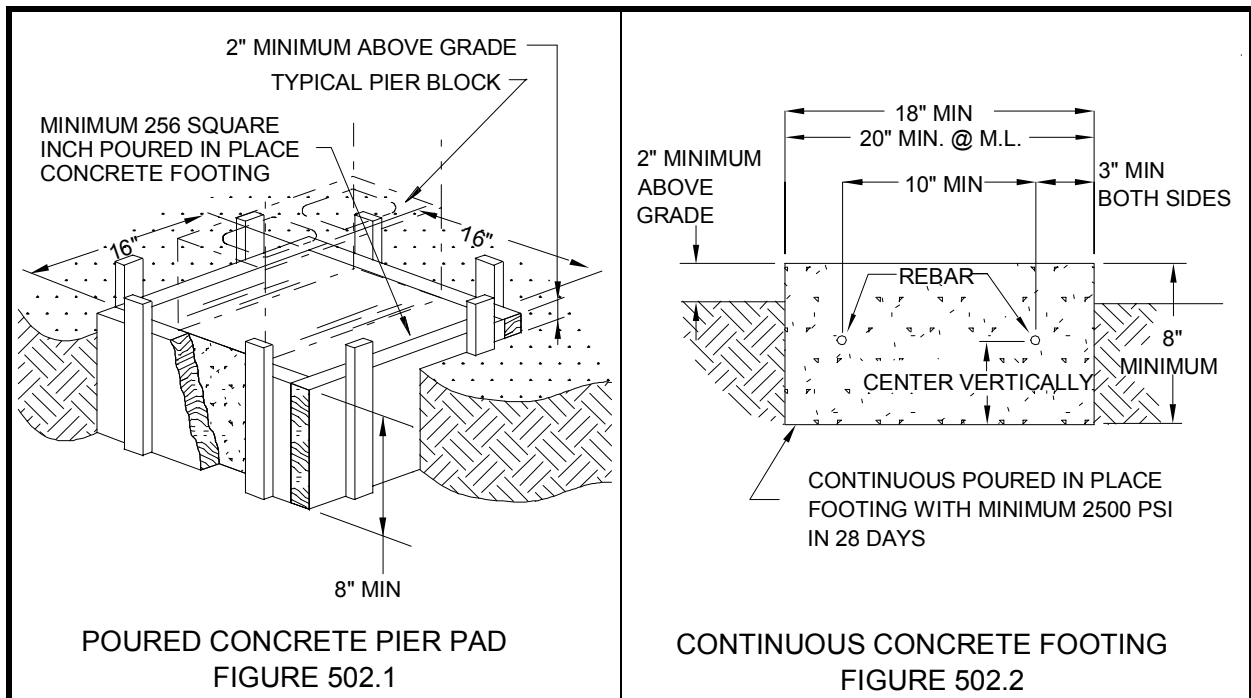

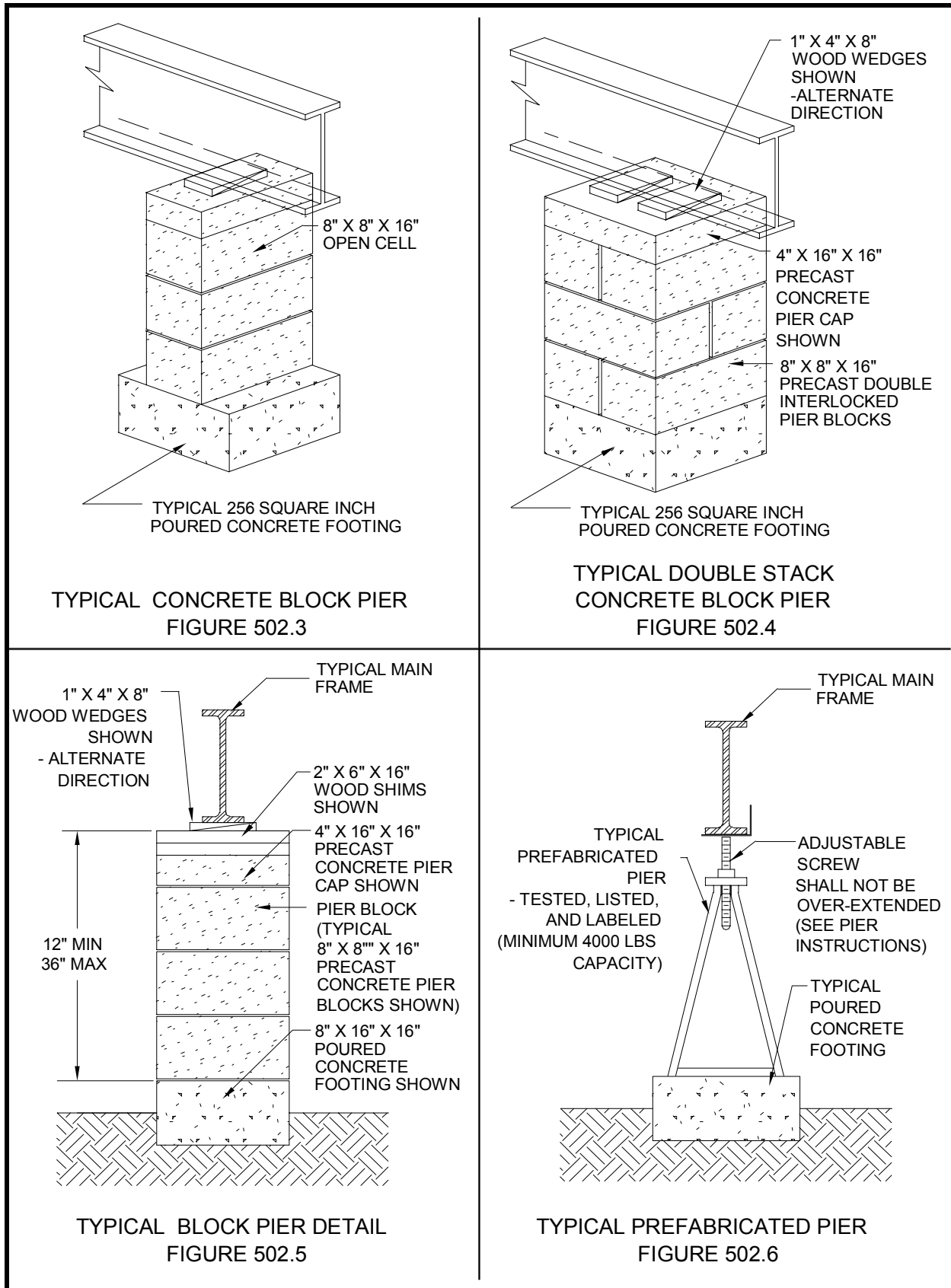

reinforcing bars. The reinforcing bars shall be centered vertically in the runner, ten inches (10") apart and shall not be closer than three inches (3") from the edge. The runner shall be centered beneath the mainframe. **See Figure 502.2.** These runners may be poured wide enough to include the outer mainframe and perimeter supports, or the inner mainframes and marriage line supports, on the same runner. If runners are poured wide enough to include two or more rows of supports two (2) continuous three-eighths inch diameter (#3) reinforcing bars shall be used for each row of supports. The reinforcing bars shall be centered vertically in the runner, spaced equidistant apart, and shall not be closer than three inches (3") nor farther than six inches (6") from the edge.

02. **Block Piers.** Concrete block piers shall be placed on approved minimum two hundred fifty-six (256) square inch (or sized as required for ridge beam column supports) footings and shall not exceed the size of the footing. Block piers shall be capped and shimmed with approved components. Piers shall be:

a. **Concrete block.** The blocks shall be either open or closed cell precast lightweight concrete of nominal size of eight inches by eight inches by sixteen inches (8" x 8" x 16"). Open cell blocks shall be positioned vertically. **See Figure 502.3.** Cinder or pumice blocks shall not be used.

(1) **Single Stack.** Block piers up to thirty-six inches (36") high under the main frame or marriage line and forty-eight inches (48") high under the perimeter walls may be single stacked. Single stacked block piers shall be placed perpendicular to the main frame and marriage line and parallel at the perimeter wall. **See Figure 502.3.**

(2) **Double Stack.** Block piers over thirty-six inches (36") high under the main frame and marriage line shall be double stacked with blocks interlocking. **See Figure 502.4.**

(3) **Maximum Height.** No concrete block piers shall be constructed over eighty inches (80") in height unless designed by an Idaho Licensed Professional engineer.

(4) **Capacity.** Single stack block piers shall be used for loads not to exceed five thousand (5,000) pounds. Double stack block piers shall be used for loads not to exceed sixteen thousand (16,000) pounds. Double and single piers may be combined for higher loads.

03. **Block Pier Caps.** Each block pier shall be capped with a pier cap equal in area to the pier blocking (i.e., 8" x 16" or 16" x 16"). **See Figures 502.3, 502.4, and 502.5.** Pier caps shall be one or more of the following.

a. **Precast Block.** A solid concrete block with a nominal thickness of four inches (4").

b. **Plywood.** One (1) piece of one and one-quarter inch (1-1/4") thick plywood, or two (2) pieces of three-quarter inch (3/4") thick plywood.

c. **Lumber.** One (1) two inch (2") nominally thick Number 2 (#2) or better grade lumber.

d. **Polymer.** One (1) two inch (2") nominally thick wood polymer composite.

e. **Other.** Listed or equivalent materials approved by the Division and the Manufactured Home Installation Committee.

04. **Block Pier Shims.** Where shim material is used between the top of the pier cap and the bottom of the main frame, the shimming

material shall not exceed five inches (5") vertically. **See Figure 502.5.** Pier shims, when used, shall be one or more of the following;

- a. **Precast Concrete.** Two inch (2") thick solid concrete blocks equal in area to the pier cap;
- b. **Plywood.** Three-quarter inch (3/4") or thicker plywood equal in area to the pier cap;
- c. **Lumber.** Two inch (2") nominally thick Number Two (#2) or better grade lumber not less than five and one-half inches (5-1/2") in width and sixteen inches (16") long;
- d. **Polymer.** One and one-quarter inch (1-1/4") minimum thickness wood polymer not less than five and one-half inches (5-1/2") in width and sixteen inches (16") long; or
- e. **Other.** Listed or equivalent materials approved by the Division and the Manufactured Home Installation Committee.

05. **Block Pier Wedges.** No more than two sets of wedges three-quarter inch (3/4") thick or one set of wedges one and one-half inches (1-1/2") thick by three and one-half inches (3-1/2") wide by eight inches (8") to sixteen inches (16") long may be used. They must be fitted perpendicular with, and driven tight to, the bottom of the main frame or floor to transfer loads uniformly to the pier. **See Figure 502.5.**

06. **Prefabricated Piers.** Prefabricated piers shall be placed on approved footings and shall not exceed the size of the footing. **See Figure 502.6.** Piers shall be:

- a. **Tested and Listed.** All prefabricated piers shall be tested, listed, and labeled for a capacity of not less than four thousand (4,000) pounds. **See Subsection 303.02.**

b. **Instructions.** The installation of the piers shall be in compliance with pier manufacturers' instructions which shall be left with the home.

c. **Shims.** No shims shall be used with a prefabricated pier.

d. **Adjustable Heads.** All piers shall be of the type fitted with an adjustable head and nut. The adjustment shall not exceed that permitted by the manufacturer's instructions.

07. **Other piers.** Other piers may be used only by approval of the Division of Building Safety and the Manufactured Home Installation Committee.

503. INSTALLATION SUPPORT REQUIREMENTS.

01. **Main Frame Supports.** The main frame of all permanent foundation set manufactured home installations shall be supported as prescribed in the following Subsections. **See Figure 503.1.** All materials and components shall comply with the requirements of **Section 303.**

a. **Footings for Permanent Foundations.** The footings for the support piers under the main frames of a permanent foundation set manufactured home shall be poured in place concrete pads. **See Subsection 502.01.a.** The homeowner may opt to have eight inch (8") thick poured concrete footing runners (**See Subsection 502.01.b.**), but they shall not be required by the local authority having jurisdiction, dealers, or installers.

(1) **Exception:** When a permanent foundation for an existing standard set home is being installed, (**See Subsection 504.02.**) any of the footings in **Subsection 402.01** which are already in place are approved.

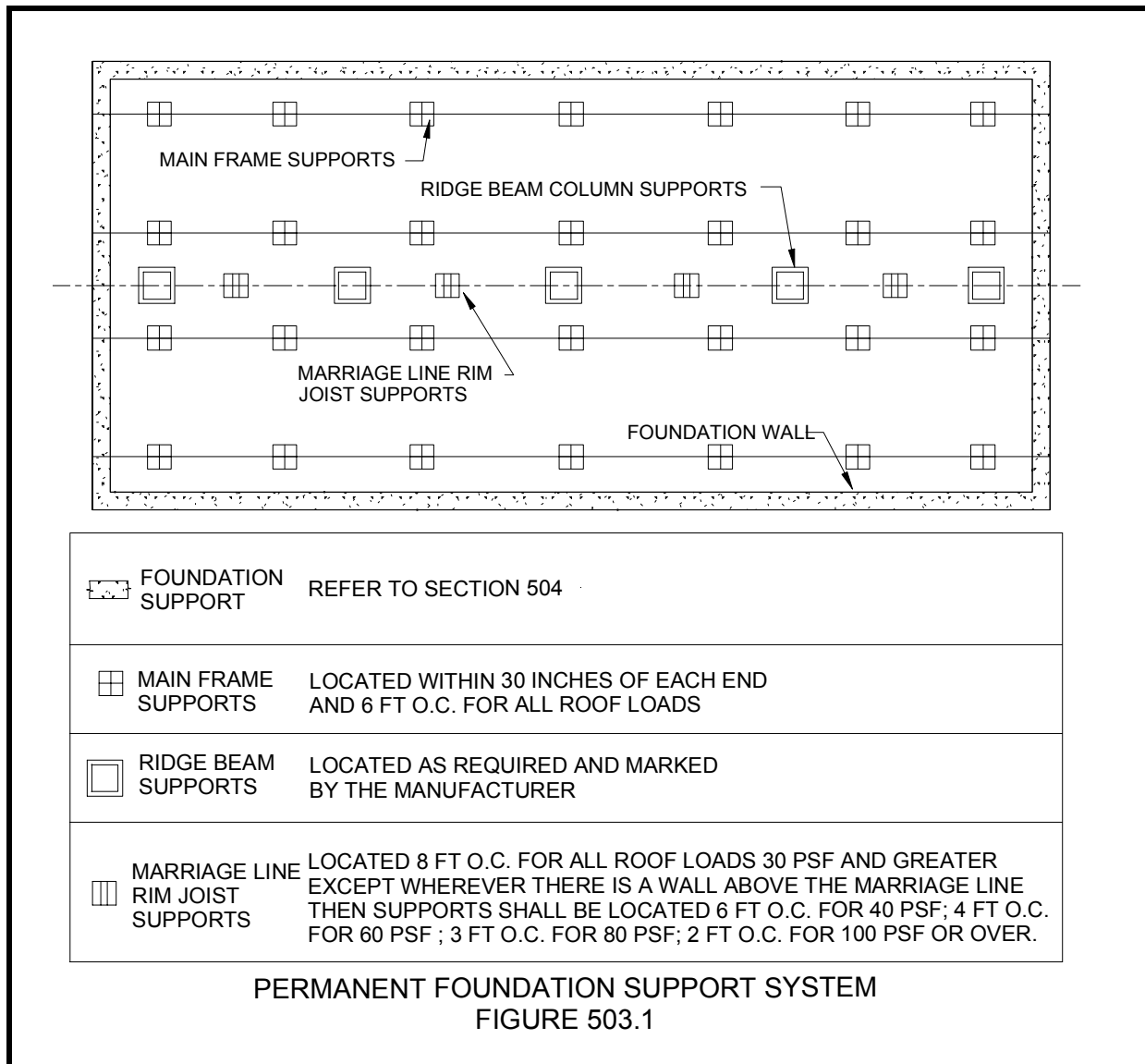

c. **Piers.** The piers for the support of main frames shall be any of the piers in **Subsections 502.02, 502.06, or 502.07.** When block piers are used they shall be placed perpendicular to the main frame.

d. **Location of Supports.** The footings and pier stands under the main frame shall be placed not more than thirty inches (30") from the ends of the frames . The footings and pier stands shall continue to be set six feet (6') on center the full length of the frame. A six inch (6") variance is allowable to clear obstructions. This spacing shall be

maintained in all roof loads up to and including one hundred twenty pounds per square foot (120 psf).

02. **Perimeter Supports.** Manufactured homes installed on a permanent foundation shall have the entire perimeter of the home supported by the foundation walls. All materials and components shall comply with the requirements of **Section 502.**

03. **Marriage line Supports.** The marriage line rim joists and ridge beam columns of permanent foundation set multi-section manufactured homes shall be supported as

prescribed in the following Subsections. **See Figure 503.1.** All materials and components shall comply with the requirements of **Section 303.**

a. Marriage Line Rim Joist Supports.

The entire marriage line shall be supported by minimum two hundred fifty-six (256) square inch poured in place footings and piers. **See Subsections 502.01, 502.02, 502.06, or 502.07.**

b. Ridge Beam Column Supports.

Marriage line roof ridge beam column supports shall comply with the requirements prescribed in the following subsections.

(1) The manufacturer shall identify in a diagram the load on, and the location of, each column. The diagram shall be provided to the homeowner, and upon request, to the dealer, installer, and local authority having jurisdiction.

(2) The manufacturer shall clearly mark the location of each column. These markings shall remain visible for inspection after the installation is completed.

(3) The installer shall use the manufacturer's diagram and markings to determine locations and loads of column supports.

(4) The installer shall use **Table 500-A** to determine the size of footing required for each column load.

(5) Footings for marriage line roof ridge beam support columns shall be constructed according to either one of the following two methods.

(a) Poured in place concrete pads a minimum of eight inches (8") nominal thickness with two (2) three-eighths

inch diameter (#3) reinforcing bars in each direction.

(b) A poured concrete footing runner a minimum of eight inches (8") nominal thickness by twenty inches (20") wide with two properly positioned three-eighths inch (#3) reinforcing bars. **See Subsection 502.01.b.**

c. Piers. Marriage line piers shall be concrete block or listed prefabricated piers. **See Subsections 502.02 and 502.06.** All ridge beam columns with a load in excess of five thousand pounds (5,000 lbs. shall have multiple blocked concrete piers or prefabricated piers listed and labeled to support the load either by itself or in combination with another pier.

d. Location of Supports. Marriage line supports shall be located as prescribed below. **See Figure 503.1.**

(1) The foundation wall shall be the first support at each end. (2) Ridge beam column supports shall be sized and located per the diagrams supplied by the manufacturer for each home and **Table 500-A.**

(3) Marriage line rim joist supports shall be located along the entire length of the marriage line as prescribed below.

(a) Eight feet (8') on center maximum for all roof loads thirty pounds per square foot (30 psf) and greater. Thirty pounds per square foot is the minimum permissible snow load rating in Idaho for new manufactured homes.

(b) Six feet (6') on center maximum for roof loads over forty and up to sixty pounds per square foot (40 to

Table 500-A				
Footing Size (Inches)	Capacity (Pounds)		Footing Size (Inches)	Capacity (Pounds)
15 x 15	2,500		29 x 29	8,500
17 x 17	3,000		30 x 30	9,000
18 x 18	3,500		31 x 31	10,000
20 x 20	4,000		32 x 32	11,000
21 x 21	4,500		34 x 34	12,000
22 x 22	5,000		35 x 35	13,000
23 x 23	5,500		37 x 37	14,000
24 x 24	6,000		38 x 38	15,000
25 x 25	6,500		39 x 39	16,000
26 x 26	7,000		40 x 40	17,000
27 x 27	7,500		42 x 42	18,000
28 x 28	8,000		43 x 43	19,000

The footing sizes shown are for square pads and are based on the area (square inches) required for the load. Other footing configurations, such as a rectangular configuration, may be used, provided the area (square inches) is equal to or greater than the area of the square footing shown in the table. For example, a 12-inch x 22-inch (264-square-inch) footing may be used in place of a 16-inch x 16-inch (256-square-inch) footing. Also, two 12-inch x 24-inch pads may be used in place of one 24-inch x 24-inch pad

60 psf) wherever there is a wall above the marriage line

(c) Four feet (4') on center maximum for roof loads over sixty and up to eighty pounds per square foot (60 to 80 psf) wherever there is a wall above the marriage line

(d) Three feet (3') on center maximum for roof loads over eighty and up to one hundred pounds per square foot (80 to 100 psf) wherever there is a wall above the marriage line.

(e) Two feet (2') on center maximum for roof loads over one hundred pounds per square foot (100 psf) wherever there is a wall above the marriage line

(f) As an alternate support system to that specified in (d) and (e) above, a marriage line pony wall may be constructed of minimum two inch by six inch (2" x 6") nominal size studs, twenty-four inches (24") on center, with double top and single (treated) bottom plates to support the marriage

line. A four inch by six inch (4" x 6") nominal size post shall be placed in this pony wall at all ridge beam support locations identified by the manufacturer. All wood shall have a structural rating equal to, or greater than, #2 SPF.

(g) Ridge beam column supports may be considered to be rim joist supports as long as the maximum allowable spacing between supports is not exceeded.

04. Height of Installation. No more than twenty-five percent (25%) of the main frame pier supports of a manufactured home shall exceed thirty-six inches (36") in height without prior approval of the local authority having jurisdiction, unless it is set on a basement. **See Section 504.03.** Pier heights shall be measured from the top of the footing to the bottom of the frame. **See Figure 502.5.** Maximum pier height shall not exceed eighty inches (80").

504. PERMANENT FOUNDATIONS.

01. Permanent Foundation. A Permanent Foundation is a perimeter supporting foundation wall which is constructed of concrete, concrete block, or pressure treated wood, on a concrete footing placed below the locally established frost depth. **See Figure 301.2.** This permanent foundation is used in conjunction with main frame and marriage line supports required in **Section 503.** Manufactured homes must be permanently affixed to a foundation to qualify as real property for tax and financing purposes.

a. **Concrete Foundation.** A poured in place perimeter concrete foundation shall comply with the requirements prescribed in the following Subsections. **See Figures 504.1A, 504.2A, and 504.2B.**

(1) **Footings.** The foundation footings shall be a minimum eight inches (8") thick by sixteen inches (16") wide of continuous poured concrete with two horizontal three-eighths inch diameter (#3) reinforcing bar.

(2) **Stem Walls.** The foundation stem wall shall be a minimum six inches (6") thick by twenty-three inches (23") high poured concrete with one horizontal three-eighths inch diameter (#3) reinforcing bar per eighteen inches (18") of height. Maximum stem wall height shall not exceed forty-eight inches (48") for over twenty-five percent (25%) of the home unless the home is installed on a basement wall as defined in **Subsection 504.03,** or the design is approved by the local authority having jurisdiction. All stem walls over thirty inches (30") in height shall have vertical three-eighths inch diameter (#3) reinforcing bar, thirty-two inches (32") on center, to tie the footing and wall together.

(3) **Sill Plate.** The stem wall shall have a sill plate of two inch by four inch (2" x 4") nominal size foundation grade redwood or pressure treated lumber attached with one-half inch by ten inch (1/2" x 10") anchor bolts six feet (6') on center and within twelve inches (12") of each corner.

b. **Block Foundation.** A concrete block wall foundation shall comply with the requirements prescribed in the following Subsections. **See Figure 504.1B.**

(1) **Footings.** The footings for a concrete block foundation shall be a minimum eight inches (8") thick by sixteen inches (16") wide continuous poured concrete with two horizontal three-eighths inch diameter (#3)

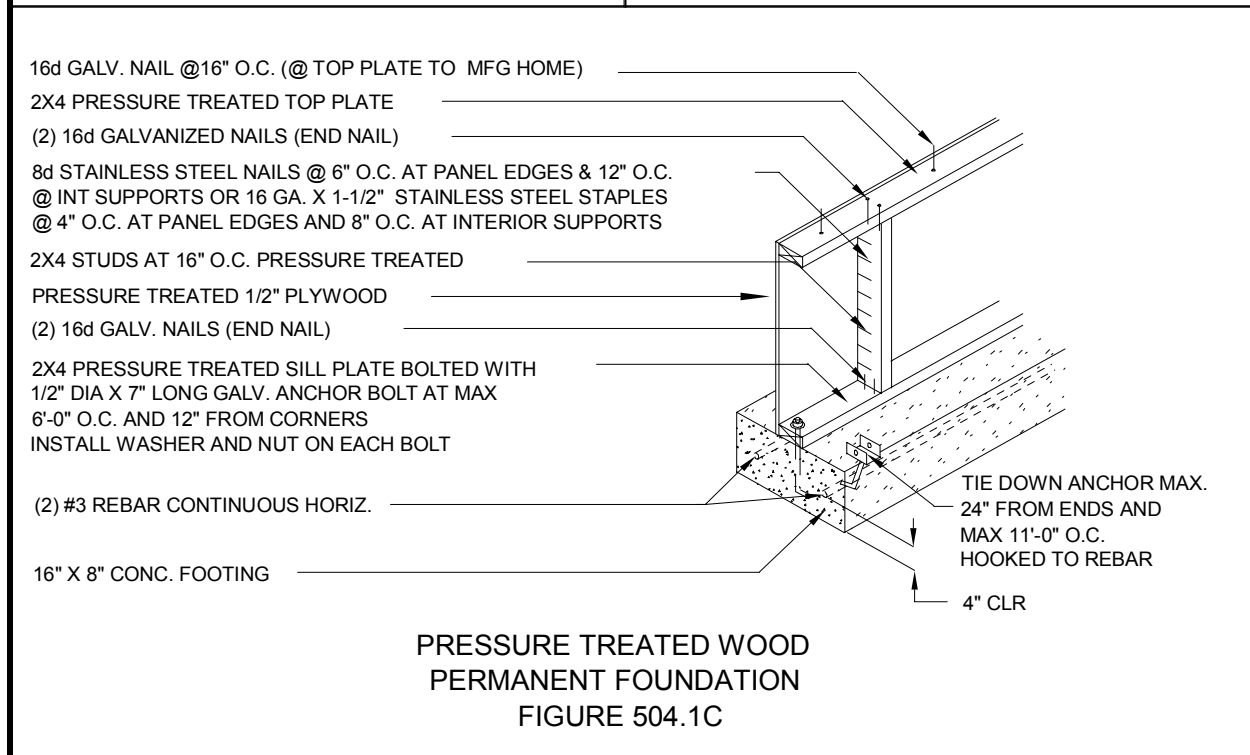
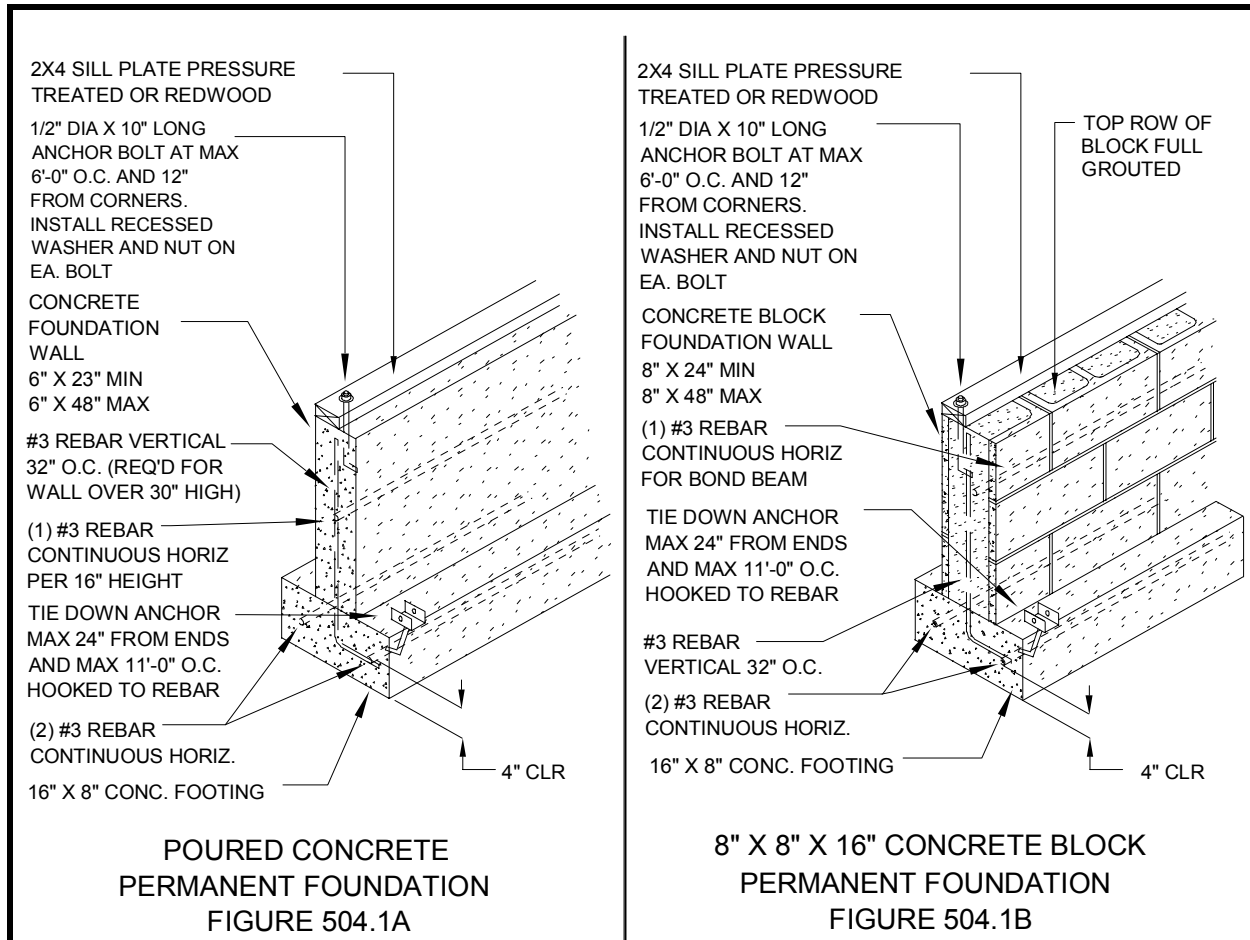

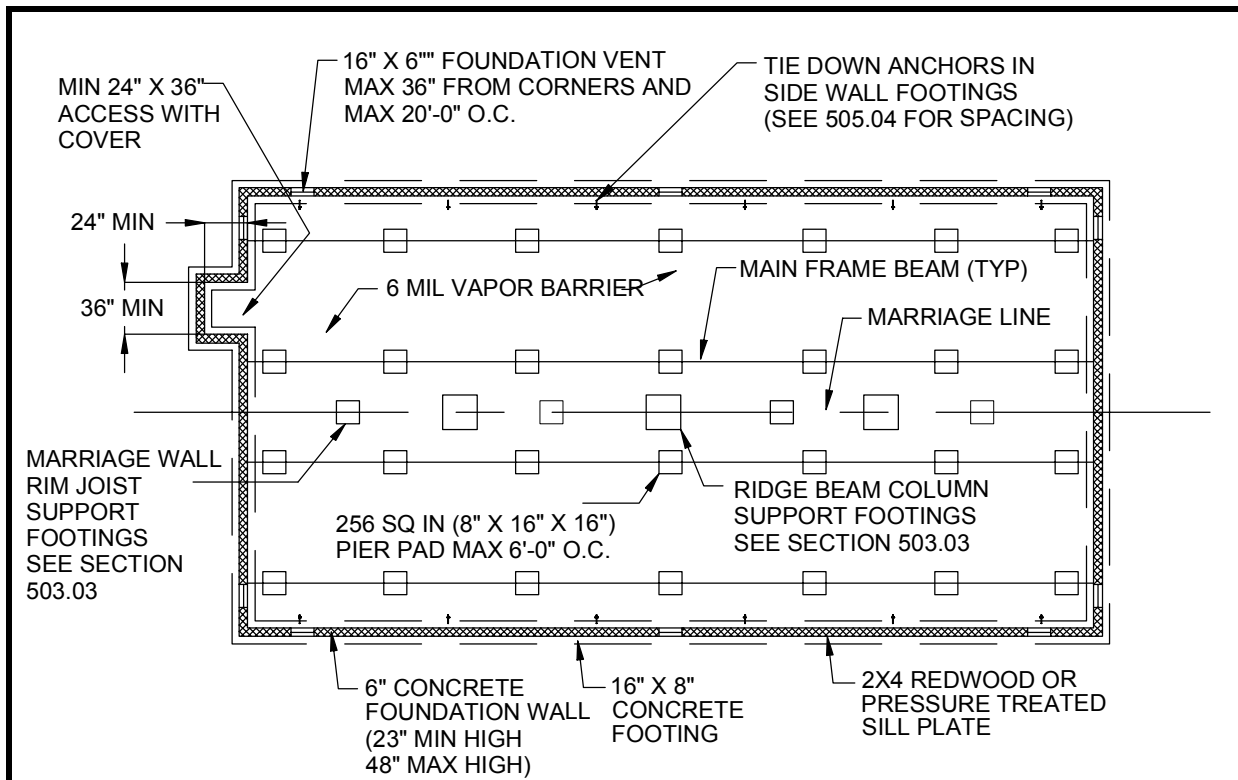

CONCRETE FOUNDATION PLAN
FIGURE 504.2A

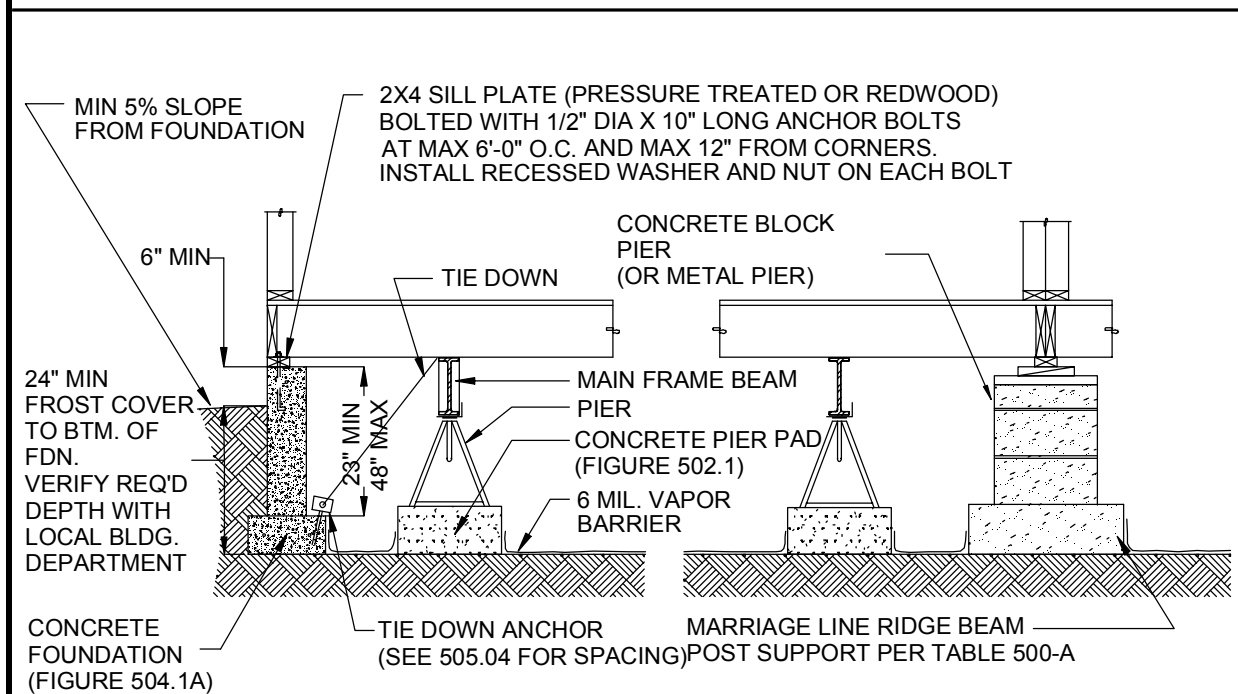

SECTION THROUGH CONCRETE FOUNDATION
FIGURE 504.2B

reinforcing bar. Vertical reinforcing bar shall be placed in the footing within twelve inches (12") of the ends and thirty-two inches (32") on center and shall extend in height to within two inches (2") of the top of the top course of blocks.

(2) **Stem Wall.** The stem walls of a block foundation shall be constructed of eight inch by eight inch by sixteen inch nominal size (8" x 8" x 16") concrete blocks mortared together for a minimum of three (3) rows and a maximum of six (6) rows. Each cell which contains a vertical reinforcing bar extending up from the footing shall be completely filled with mortar. A three-eighths inch diameter (#3) reinforcing bar shall be placed in the top course to form a bond beam and all cells in the top course of blocks shall be filled with grout.

(3) **Sill Plate.** The stem wall shall have a sill plate of two inch by four inch (2" x 4") nominal size foundation grade redwood or pressure treated lumber attached with one-half inch by ten inch (1/2" x 10") anchor bolts grouted in the block space a maximum of six feet (6') on center and within twelve inches (12") of each corner.

c. **Pressure Treated Wood Foundation.** A foundation of pressure treated lumber shall comply with the requirements prescribed in the following Subsections. See **Figure 504.1C**.

(1) **Footings.** The footings for a pressure treated lumber foundation shall be a minimum eight inches (8") thick by sixteen inches (16") wide continuous poured concrete with two horizontal three-eighths inch diameter (#3) reinforcing bar. The footing shall have

one-half inch by seven inch (1/2" x 7") anchor bolts within twelve inches (12") of each corner and six feet (6') on center to secure the bottom plate of the stem wall to the footing.

(2) **Stem Wall.** The stem wall shall be a minimum of twenty-four inches (24") and a maximum of forty-eight inches (48") in height. It shall be constructed of two inch by four inch (2" x 4") nominal size pressure treated studs spaced sixteen inches (16") on center with pressure treated top and bottom plates. The top plate shall be fastened to the bottom of the home with galvanized three and one-half inch (3 1/2") long (16d) nails. It shall have an exterior enclosure of pressure treated plywood secured on all studs and plates with stainless steel fasteners. The pressure treated plywood shall be fifteen-thirty seconds inch (15/32") thick with a thirteen-sixteenths (13/16) span index for walls up to thirty-two inches (32") high and nineteen-thirty seconds inch (19/32") thick with a forty-twentieths (40/20) span index for walls higher than thirty-two inches (32"). The stainless steel fasteners shall be either two and one-half inch (2 1/2") long (8d) nails at six inches (6") on center on all edges and twelve inches (12") on center on interior studs, or sixteen (16) gauge one and one-half inch (1 1/2") staples at four inches (4") on center on all edges and eight inches (8") on center on interior studs. All wood shall be pressure treated according to AWWA standards and shall be stamped AWWA FDN.

d. **Other Permanent Foundation Designs.** Other permanent foundation systems that are engineered and stamped

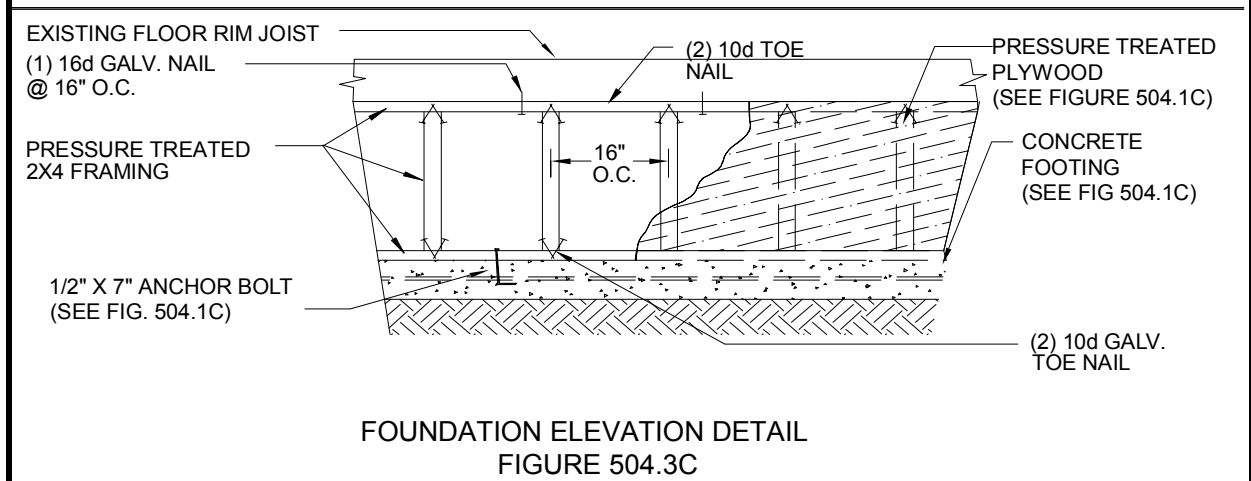
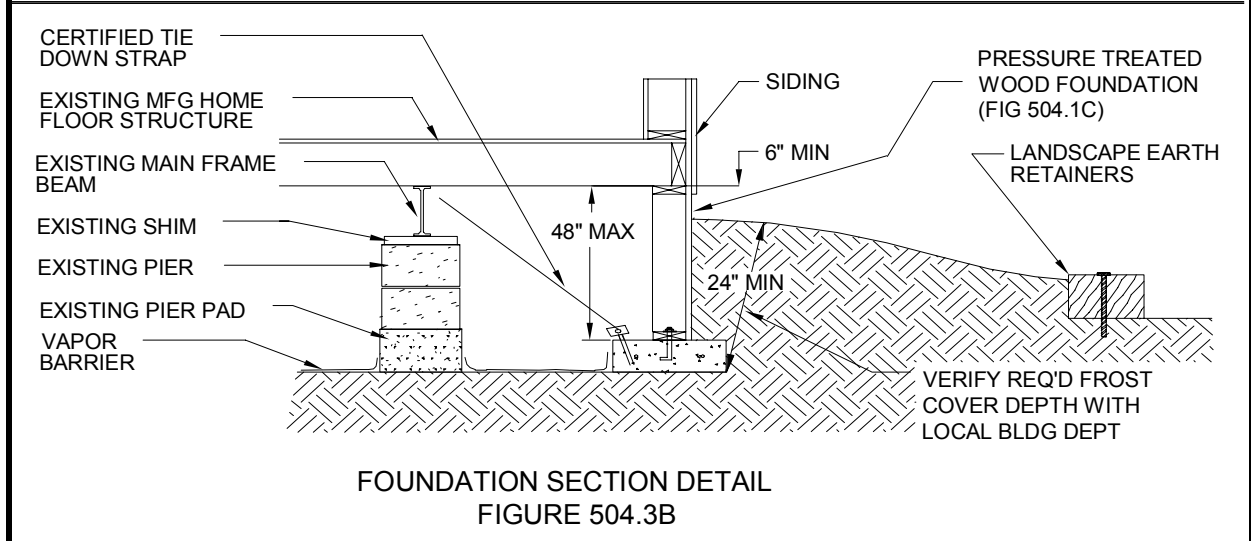
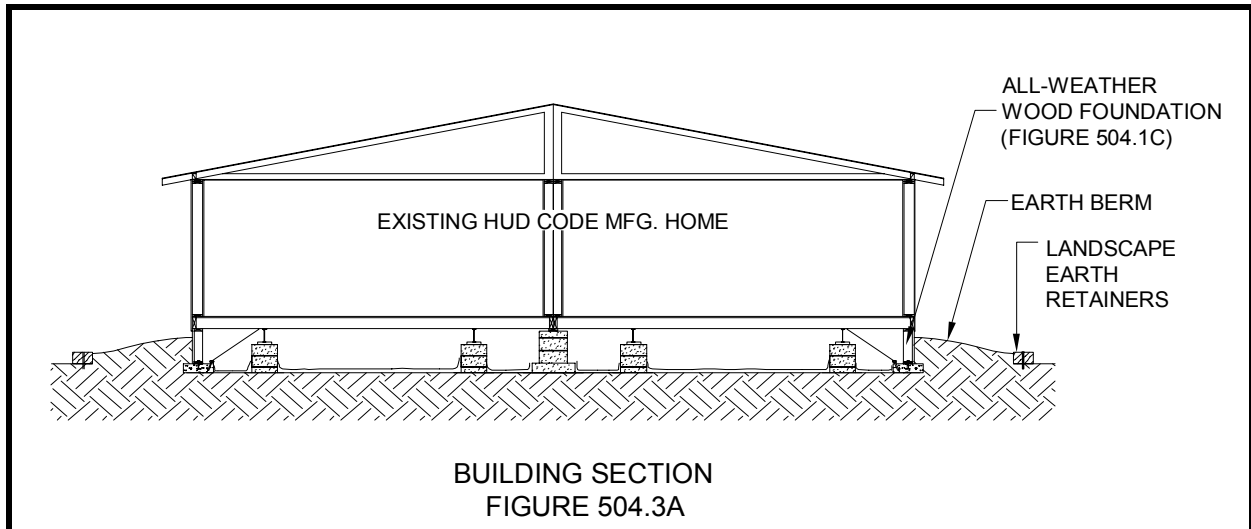

ALL WEATHER WOOD FOUNDATION FOR AN EXISTING MFG. HOME
FIGURES 504.3A, 504.3B, 504.3C

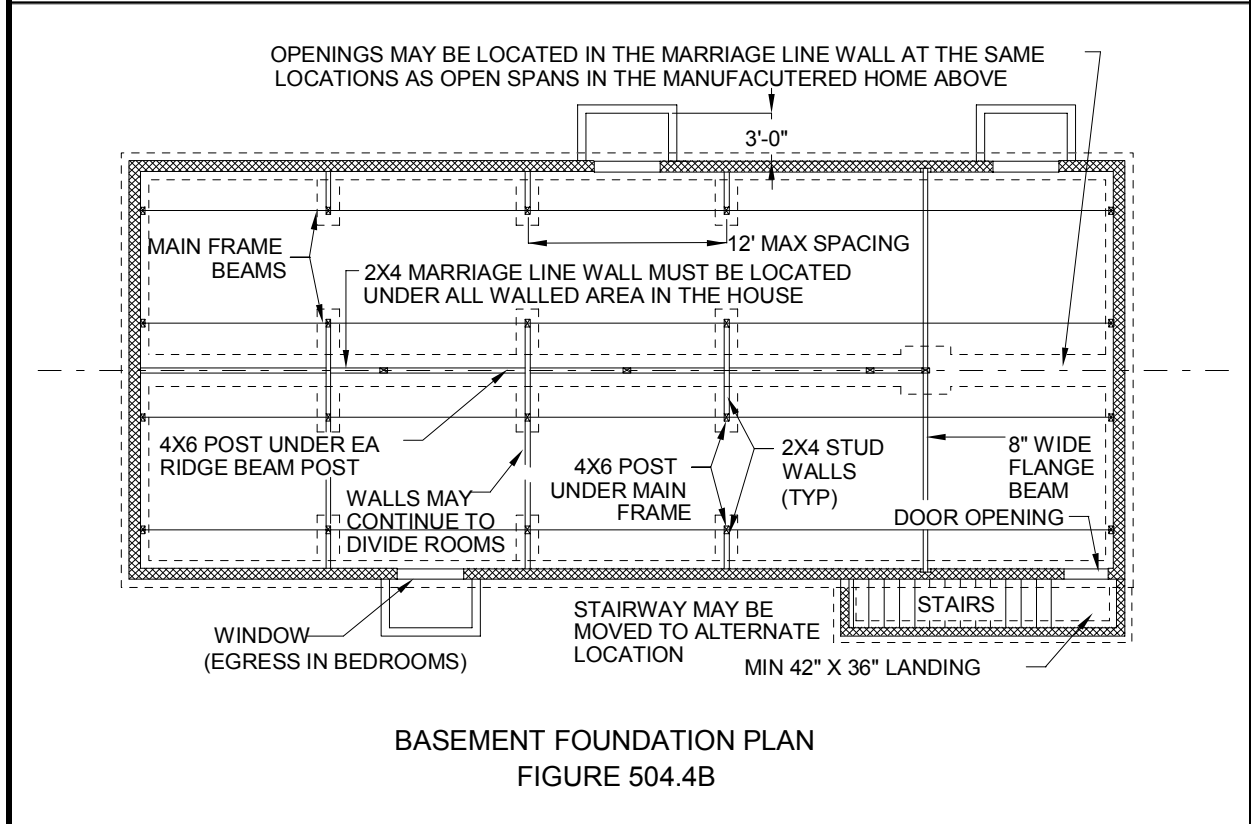
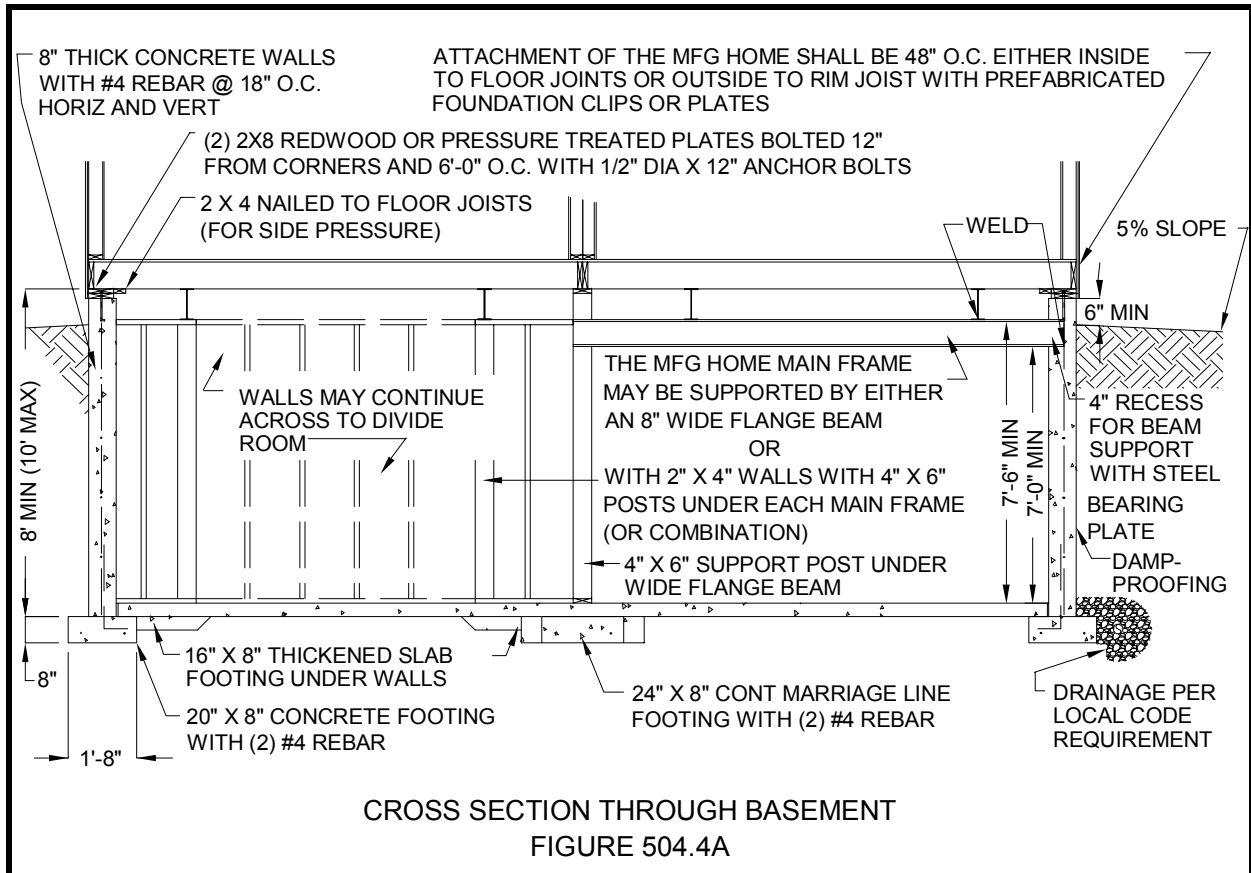

by an Idaho Licensed Professional Engineer, and which have been approved by the Division and the Manufactured Home Installation Committee, may be used.

f. **Frost Protection.** All footings for permanent foundations shall be placed a minimum of twenty-four inches (24") below grade, or according to the accepted frost level of the jurisdiction. Footings shall be on undisturbed or engineered and tested compacted soil.

g. **Vents.** All foundations shall be vented within three feet (3') of each corner and with twenty foot (20') maximum spacing.

h. **Installation.** The manufactured home is to be installed with the perimeter walls supported on the foundation wall and the main frames supported according to **Subsection 503.01**. The marriage line shall be supported in accordance to **Subsection 503.03**.

i. **Recesses and Decks.** When a manufactured home has a factory installed deck, porch, or recessed entry larger than thirty-six (36) square feet which has open decking a stem wall shall encompass that area to separate it from the remainder of the foundation. The stem wall shall have a footing, and be a minimum of twelve inches (12") high. No vapor barrier shall be installed under this open deck area.

02. Foundations for Existing Home. Existing standard set manufactured homes (**See Figure 301.1**) may be converted to a permanent foundation set by placing the home onto any one of the three foundations described in **Section 504**.

a. If a concrete or block stem wall (**Subsection 504.01.a(2)** or **Subsection 504.01.b(2)**) is used, the home will need to be raised (or moved) in order to pour

concrete into wall forms or to fill the cells of the concrete blocks, and to attach the sill plate. The home will be then placed back onto the foundation.

b. If a pressure treated foundation (**See Subsection 504.01.c.**) is used, the top plate shall be secured to the bottom of the home with three and one-half inch (3 1/2") long (16d) galvanized nails and the bottom plate shall be bolted to the footing. The studs of the stem wall shall be tightly fitted between the top and bottom plates and toe nailed with three inch (3") long (10d) galvanized nails to provide support under the walls of the home. **See Figure 504.3C**. The exterior enclosure shall be according to **Subsection 504.01.c(2)**. Installing this system does not require the home to be raised.

c. The footings must be below frost depth but no less than twenty-four inches (24") below grade. The foundation wall must be backfilled to that depth. The grade must be sloped a minimum of five percent (5%) from the foundation wall. A "flower bed" effect may be created by placing landscape ties or timbers three feet (3') from the home and then filling this area with backfill. **See Figures 504.3A and 504.3B**.

d. Check and correct the supports under the main beams (**See Subsection 503.01.a(1)**) and marriage line. **See Subsection 503.03**. All ridge beam support columns must be on footings of minimum five hundred twelve (512) square inches.

e. Check to ensure a vapor barrier is in place under the home. If there is no barrier, install a six one-thousandths inch thick (.006") black membrane vapor retarder. **See Subsection 302.06**.

03. Basement Perimeter Support Foundation. A single or double section

manufactured home may be placed on a basement constructed as follows: **See Figures 504.4A and 504.4B.**

a. **Wall Footing.** The perimeter footing shall be eight inches (8") thick by twenty inches (20") wide concrete reinforced with two (2) one-half inch diameter (#4) reinforcing bar.

b. **Walls.** The perimeter walls shall be concrete eight inches (8") thick by a minimum eight feet (8') and a maximum of ten feet (10') high reinforced vertically and horizontally every eighteen inches (18") with one-half inch diameter (#4) reinforcing bar. The wall shall have a double two inch by eight inch (2" x 8") nominal size redwood or pressure treated sill plate attached to the wall with one-half inch by twelve inch (1/2" x 12") anchor bolts one foot (1') from each corner and spaced six feet (6') on center.

c. **Marriage line Footing.** The centerline footing shall be eight inches (8") thick by twenty-four inches (24") wide with two (2) one-half inch diameter (#4) reinforcing bar. Widen the footing to thirty-six inches (36") for two feet (2') on each side of any marriage line post which supports a cross supporting I-beam. **See Subsection 504.03.d(2).**

d. **Support System.** The manufactured home main frame beams shall be supported by either of the following two methods, or a combination of the following two methods.

(1) Cross walls of standard two inch by four inch (2" x 4") nominal size stud construction spaced a maximum of every twelve feet (12'). Each wall shall have a four inch by six inch (4" x 6") nominal size post located directly under each main frame beam. These walls may extend across from the basement wall to

the centerline but are only required to extend to the I-beam support post. **See Figures 504.4A and 504.4B.** The bottom plate must be secured to the floor to prevent movement.

(2) An eight inch (8") by fifteen pounds per foot (15 lb/ft) I-beam may be supported by four inch (4") deep pockets in the concrete wall and by four inch by six inch (4" x 6") nominal size posts in the centerline wall. Each cross beam shall be welded at each end to a three-eighths inch (3/8") thick plate secured into the concrete wall pocket. Each cross beam shall also be welded to the home's main frame beams at each point of contact. Maximum spacing between beams shall be twelve feet (12').

(3) Note that support walls or beams placed at the maximum spacing of twelve feet (12') will allow the home to incur more floor vibrations than it will if the walls or beams are positioned more closely together.

e. **Floor.** The floor shall be a nominal four inch (4") thick concrete slab poured over a compacted sand and gravel base. The slab shall be thickened to eight inches (8") by sixteen inches (16") wide under all cross walls. **See Subsection 504.03.d(1).**

f. **External Pressure.** A two inch by four inch (2" x 4") nominal size board shall be nailed with three and one-half inch (3 1/2") long (16d) nails to the home's floor joists along the sill plate on the side walls to counter external pressure on the walls. **See Figure 504.4A.** This may be eliminated if either the cross walls or I-beams extend continuous across the basement.

g. **Ceiling Height.** The minimum height from the top of the concrete floor to a

ceiling which may be attached to the manufactured home main frame beams shall be seven feet six inches (7'-6"). If cross I-beams are used to support the manufactured home main frame beams (See Subsection 504.03.d(2)) the minimum distance from the top of the concrete floor to the bottom of the I-beams shall be seven feet (7'-0").

h. **Marriage line Wall.** A marriage line wall constructed of two inch by four inch (2" x 4") nominal size studs, 16" on center, with double top and single bottom plates shall support the marriage line the entire length of the home. The bottom plate shall be bolted to the concrete floor with one-half inch by ten inch (1/2" x 10") anchors spaced forty-eight inches (48") on center. A four inch by six inch (4" x 6") nominal size post shall be placed in this wall at all ridge beam support locations. The wall studs and posts shall be one piece from floor plate to top plate. Openings over three feet (3') in width may only be located in this wall at the same locations as open spans in the home above.

i. **Anchors.** The manufactured home shall be anchored to the foundation by one or the other of two following methods.

(1) The use of prefabricated foundation clips or plates located every forty-eight inches (48") either inside or outside the sill plate.

(2) If the home is totally supported by cross I-beams, the I-beams shall be welded to the home's main frame beams at each point of contact.

j. **Other Designs.** Other engineered basement plans designed and stamped by an Idaho Licensed Engineer and approved by the local authority having jurisdiction may be used.

04. **Grading.** After all aspects of the foundation is complete, the site shall have adequate grading as prescribed in Section 302 of this standard.

05. **Drainage.** The contractor shall assure that proper drainage is provided around a basement or foundation in a high ground water location in compliance with the requirements of the local authority having jurisdiction.

06. **Real Property Designation.** Any home placed on a foundation built according to Section 504 qualifies for designation as real property.

07. **Permits and Inspections.** Building permits and inspections are required in any jurisdiction having a building code. Permits must be obtained prior to construction. See Section 201.

505. ANCHORING.

01. **Anchoring.** To resist lateral movement from high winds, earthquakes, and flooding, all manufactured homes installed on permanent foundations shall have manufactured and approved anchoring devices capable of resisting loads prescribed in Section 505.02.

02. **Loads.** Anchoring equipment including all anchors, straps, and tension devices used to secure a manufactured home when installed, shall be capable of resisting an allowable working load at least equal to or exceeding three thousand one hundred-fifty pounds (3,150 lbs) and shall be capable of withstanding fifty percent (50%) overload (4,725 lbs) without failure of either the anchoring equipment or the attachment point to the manufactured home. When the stabilizing system is designed by a qualified Idaho Licensed Engineer, alternate working loads may be used, provided the anchoring equipment is capable of withstanding a fifty percent (50%) overload.

03. **Ties.** All tie strapping shall be fastened to anchors and drawn tight with adjustable tensioning devices supplied with the anchor.

a. Tie strapping shall be certified and listed to be capable of resisting an allowable working load of three thousand one hundred-fifty pounds (3,150 lbs) with no more than two percent (2%) elongation and shall withstand a fifty percent (50%) overload.

b. Ties shall connect the anchor to the main frame I-beams which run lengthwise under the manufactured home. Ties shall not connect to steel outrigger or cross member beams which fasten to, and intersect with, the main frame I-beams.

c. Tie materials shall be designed to prevent self-disconnection when ties are slack. Open hook ends shall not be used in any part of the anchoring system. See **Figure 505.1**

04. **Spacing.** Unless otherwise specified in the anchoring equipment manufacturer's installation instructions, anchors shall be placed in the sidewall footing within two feet (2') from each corner and spaced as follows: (Also see **Figure 504.2A**, **504.2B** and **Section 505**.) Eleven feet (11') maximum on center for homes up to eighteen feet (18') in height (maximum ground to roof peak) in a seventy mile per hour (70 mph) wind zone, or up to fourteen feet (14') in height for an eighty mile per hour (80 mph) wind zone. For homes from fourteen feet (14') to eighteen feet (18') in height in an eighty mile per hour (80 mph) wind zone, space anchors eight feet (8') maximum on center.

05. **Certification.** Anchoring equipment is certified when tested, listed, and labeled by a nationally recognized testing and listing laboratory, or designed by a Idaho Licensed Professional Engineer and approved by the

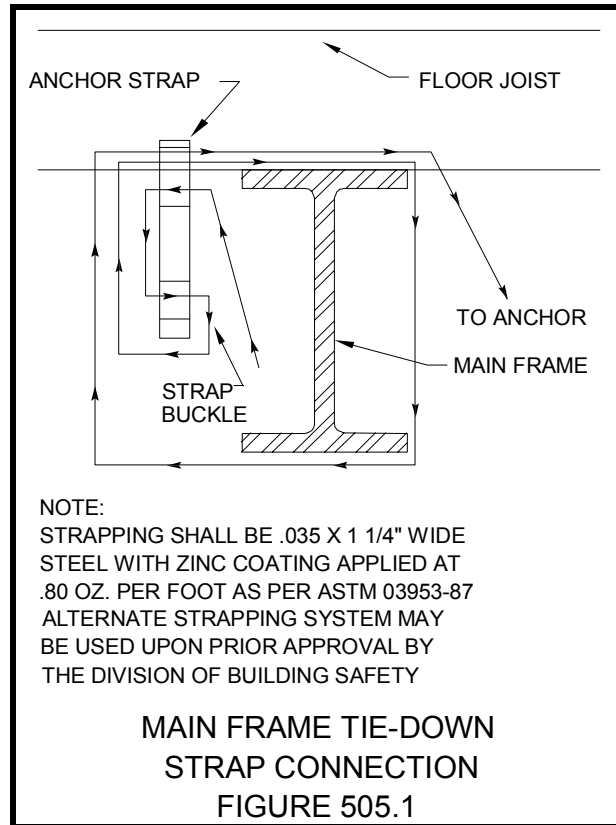

Division of Building Safety and the
Manufactured Home Installation Committee.

06. **Alternate anchoring systems.** Alternate anchoring systems may be used when approved by the Division and the Manufactured Home Installation Committee.

506. -- 599. RESERVED.

This page intentionally blank

Chapter 6 ELECTRICAL CONNECTIONS

601. GENERAL.

01. **Installation.** All electrical work in connection with a manufactured home installation, alteration, repair, conversion, or addition, shall be performed according to the National Electrical Code by a Idaho Licensed Electrical Contractor or by the homeowner. A permit is required for all electrical work.

602. ELECTRICAL FEEDER CONNECTIONS.

01. **Power Supply.** A manufactured home power supply shall be provided according to Article 550-24 of the National Electrical Code. All connections shall be made by an Idaho Licensed Electrical Contractor or the homeowner.

603. SERVICE EQUIPMENT CONNECTION.

01. **Service Equipment on Manufactured Home.** As permitted by Article 550-23(b) of the National Electrical Code and 24 CFR 3280.803, service equipment may be permanently installed on a manufactured home if:

- a. The service equipment is installed by the manufacturer at the manufacturing plant during initial construction or is installed on-site in a manner prescribed by Article 550-23(b) of the 1999 National Electrical Code provided the home was manufactured after January 1, 1992;
- b. The service equipment is installed according to Article 230 of the National Electrical Code;
- c. The service equipment is installed on the manufactured home as close as

possible to the site's electrical service as designated by the applicable electric utility company; and

d. The service equipment is grounded according to Article 250 of the National Electrical Code.

Note. The following information is not adopted as part of this standard but is referenced in this standard for the convenience of the user. Users should review the code provisions cited to determine if any of the requirements have changed.

a. Article 550-23(a) of the National Electrical Code requires that manufactured home service equipment be readily accessible, be located in sight of the manufactured home, and shall not be located more than thirty feet (30') from the exterior wall of the manufactured home.

02. **Service Clearances.** Service conductors shall maintain the overhead clearances required by Article 230-24 of the National Electrical Code. Underground installation clearances shall be as required by Article 300 of the National Electrical Code or as may be required by the electric utility company. **See Figure 603.1.**

604. ELECTRICAL CROSSOVER CONNECTIONS.

01. **Crossover Connection.** Each circuit shall be connected to the corresponding color coded or marked circuit of the adjacent section in an approved manner. The connection shall be made by an Idaho Licensed Electrical Contractor or the homeowner.

02. **Chassis Bonding.** Each chassis shall be bonded to the adjacent chassis with a solid or

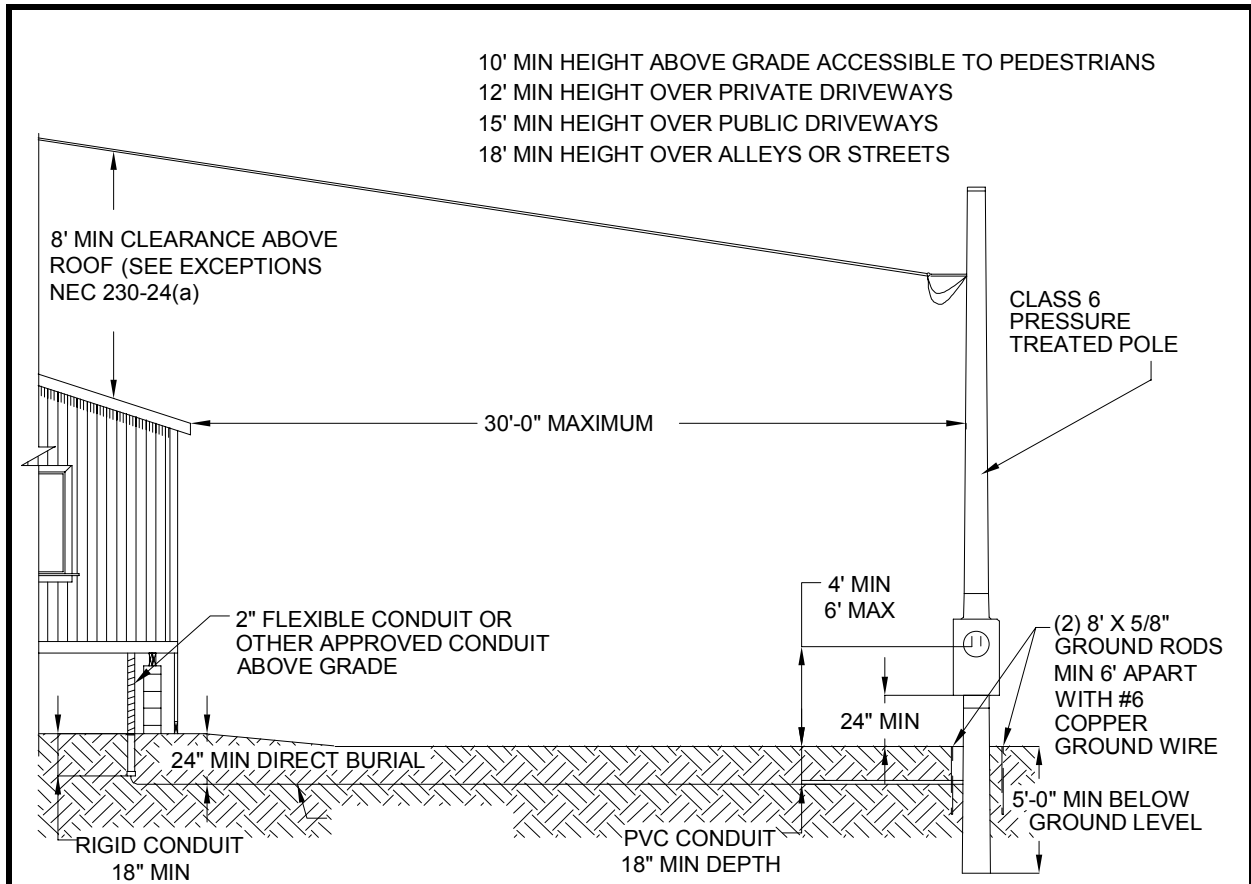

**SERVICE CONDUCTOR CLEARANCES
UNDERGROUND FEEDER
FIGURE 603.1**

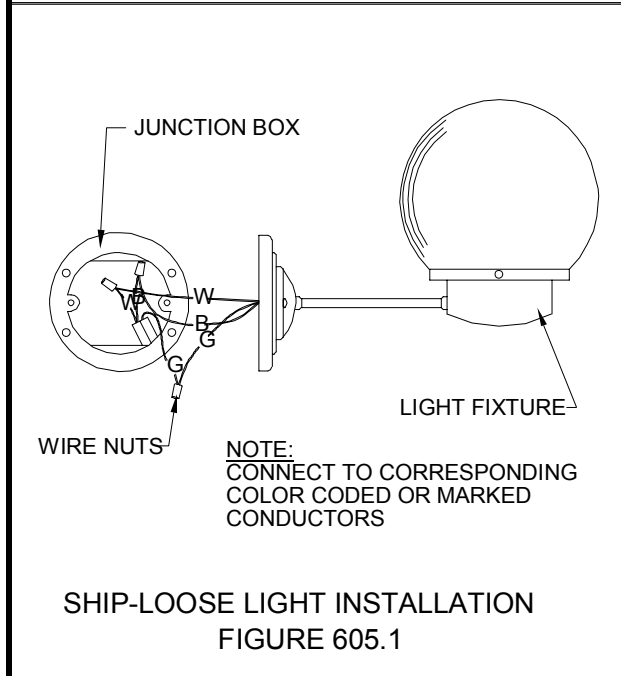

**SHIP-LOOSE LIGHT INSTALLATION
FIGURE 605.1**

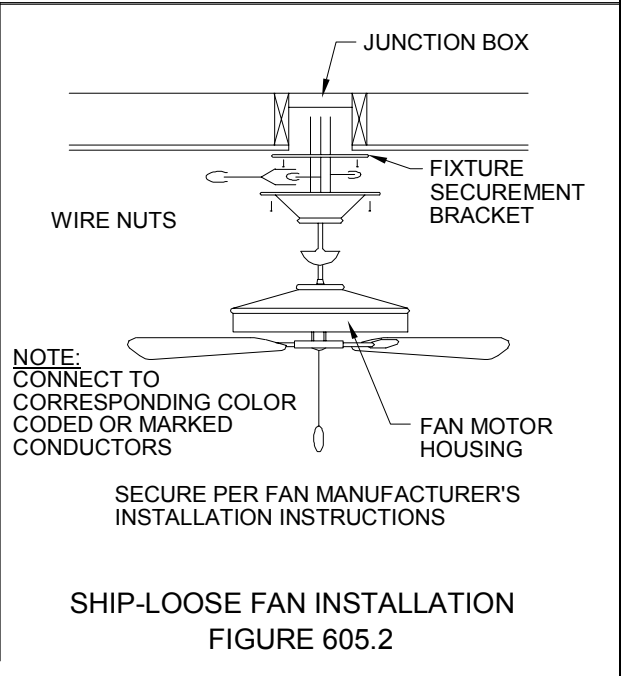

**SHIP-LOOSE FAN INSTALLATION
FIGURE 605.2**

stranded, green insulated or bare, No. 8 copper conductor, or by an equal bonding method.

605. ELECTRICAL EQUIPMENT.

01. Shipped Loose Equipment. Electrical equipment such as ceiling fans, chandeliers, exterior lights, and mechanical equipment which are shipped loose with the manufactured home shall be installed on-site according to the National Electrical Code, and the product manufacturer's listings. Wiring connections of shipped-loose electrical equipment shall be connected to the corresponding color coded or marked conductors to all applicable provisions of the National Electrical Code. **See Figures 605.1 and 605.2.**

02. Bonding Strap Removal. 240 volt appliances, such as ranges and dryers, shall have the bonding strap between the ground and neutral conductors removed before installation in a manufactured home. Cords used on 240 volt appliances shall have 4 conductors and 4 prongs when connected to a manufactured home.

606. ELECTRICAL TESTING.

01. Testing. At the time of installation, all manufactured homes shall be tested as follows:

- a. All 120 volt electrical receptacle outlets shall be subjected to a polarity test to assure that connections have been made properly;
- b. All shipped-loose fixtures shall be subjected to a polarity test to assure that connections have been made properly;
- c. All receptacles protected by a ground fault circuit interrupter (GFCI) shall be tested with a GFCI tester;
- d. All grounding and bonding conductors installed or connected during the

manufactured home installation shall be tested for continuity; and

e. All electrical lights, equipment, ground fault circuit interrupter, and appliances shall be subjected to an operational test to demonstrate that all equipment is connected and in working order.

607. -- 699. RESERVED.

This page intentionally blank

Chapter 7 PLUMBING CONNECTIONS

701. GENERAL.

01. **Connections.** Plumbing installations involving the connection of the manufactured home to the site water and sewer utilities shall be plumbed according to the Idaho State Code 54-2601 and the Uniform Plumbing Code.

02. **Installer.** Plumbing installations to connect the manufactured home to site water and sewer utilities may be performed by any one of the following:

- a. A manufactured home installer with a specialty contractor license or journeyman's license, (which limits the work to under the perimeter of the home).
- b. Idaho State Licensed Plumber.
- c. The homeowner.

03. **Location.** All site utility plumbing installations outside the fixed limits of the perimeter of the manufactured home shall be installed by a licensed plumbing contractor, excavator, or the homeowner.

04. **Permits.** All plumbing installations require a permit and an inspection by a state authorized inspector.

702. SHIP-LOOSE PLUMBING.

01. **Ship-Loose Plumbing.** Manufactured home underfloor drain pipe systems may be shipped by the manufacturer in one of the following methods:

- a. Complete and ready to be connected to the site sewer utility;
- b. Loose in one or more pre-assembled sections to be attached to the site sewer utility;

c. Loose sections intended to be assembled on-site as approved by the DAPIA and in accordance with the manufacturer's instructions.

703. WATER CONNECTIONS.

01. **Water Connections.** The installation and connection of the manufactured home water distribution system to the site water utility shall be limited to under the perimeter of the home, and shall be done by a Licensed Manufactured Home Installer, a Licensed Plumbing Contractor or the homeowner. The installation shall require a permit and shall be inspected.

02. **Material.** Water service pipe installed to a manufactured home shall be of approved type material, UPC, Section 1004.

Note. The following information is not adopted as part of this standard but referenced in this standard for the convenience of the user. Users should review the code provisions cited to determine if any of the requirements have been changed.

- a. As required by the Uniform Plumbing Code, Section 1005, an accessible full way shutoff valve shall be provided on the water supply serving the manufactured home.
- b. As required by the UPC, Section 1009, the water inlet shall be connected to the site water supply by an approved connector not less than three-quarter inch (3/4") nominal diameter.
- c. As required by the UPC, Section 1007-B, where static water pressure exceeds eighty pounds per square inch (80 psi) at

the supply, a pressure reducing valve shall be installed.

d. As required by the UPC, Section 315-F, water inlets shall be protected from freezing by insulating the pipe and/or using an electric heat tape listed for use with manufactured homes.

e. As required by 24 CFR 3280.609(b), the water pipe crossover on multi-section manufactured homes shall be connected with the connectors supplied by the manufacturer. See **Figures 703.1** and **703.2**. When the manufacturer's connector is not available the connector shall consist of an approved flexible water connector sized no less than the waterlines being connected or shall be fabricated from other approved materials. Exposed water line crossover connections shall be insulated to protect them from freezing.

f. As required by the UPC, Section 1007-E, water heater pressure relief valve drain pipes shall not be terminated, nor allowed to discharge, beneath manufactured homes but shall be extended to the exterior of the perimeter of the home.

g. Water service shall be installed according to the following requirements:

(1) No water pipe shall be installed or permitted outside of a building or exterior wall unless adequate provisions are made to protect the pipe from freezing.

(2) There shall be no connections between potable and non-potable water.

03. Water Valve Access. The full way main valve shall be installed between the water service utility and the manufactured home

connection, within the crawl space enclosure at a readily accessible location.

04. Water Utility Size. The size of water service required shall be determined by referring to UPC chapter 10, Tables 101 and 102. The minimum requirement is a three-quarter inch (3/4") nominal size service line.

704. DRAIN AND SEWER CONNECTIONS.

01. Drain Connection. The installation and connection by a Licensed Manufactured Home Installer of the manufactured home drain to the sewer utility shall be limited to under the perimeter of the home. Installation outside the perimeter of the home shall be according to Idaho State Code 54-2602, A-F.

Note. The following information is not adopted as part of this standard but referenced in this standard for the convenience of the user. Users should review the code provisions cited to determine if any of the requirements have been changed.

a. As required by 24 CFR 3280.610(c), each manufactured home shall have only one drain outlet.

b. As required by 24 CFR 3280.610(c), each manufactured home shall be connected to the sewer inlet by means of a drain connector consisting of approved pipe fittings schedule 40 or heavier and a nominal size of three inches (3") or larger. Listed and approved flexible connectors shall be used to connect the drain pipe to the sewer inlet.

c. As required by 24 CFR 3280.610, the drain pipe crossover on multi-section manufactured homes shall be connected with the connectors supplied by the manufacturer, or when not available, shall

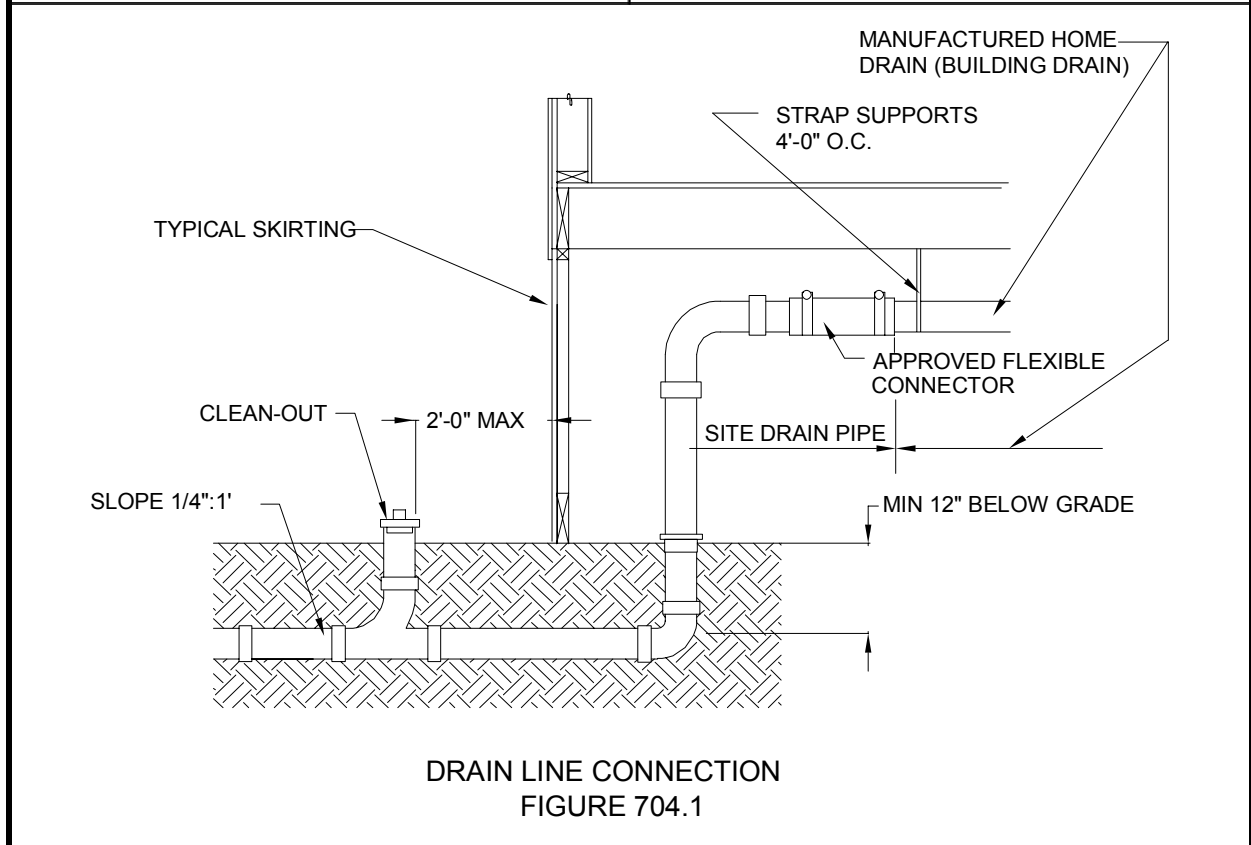
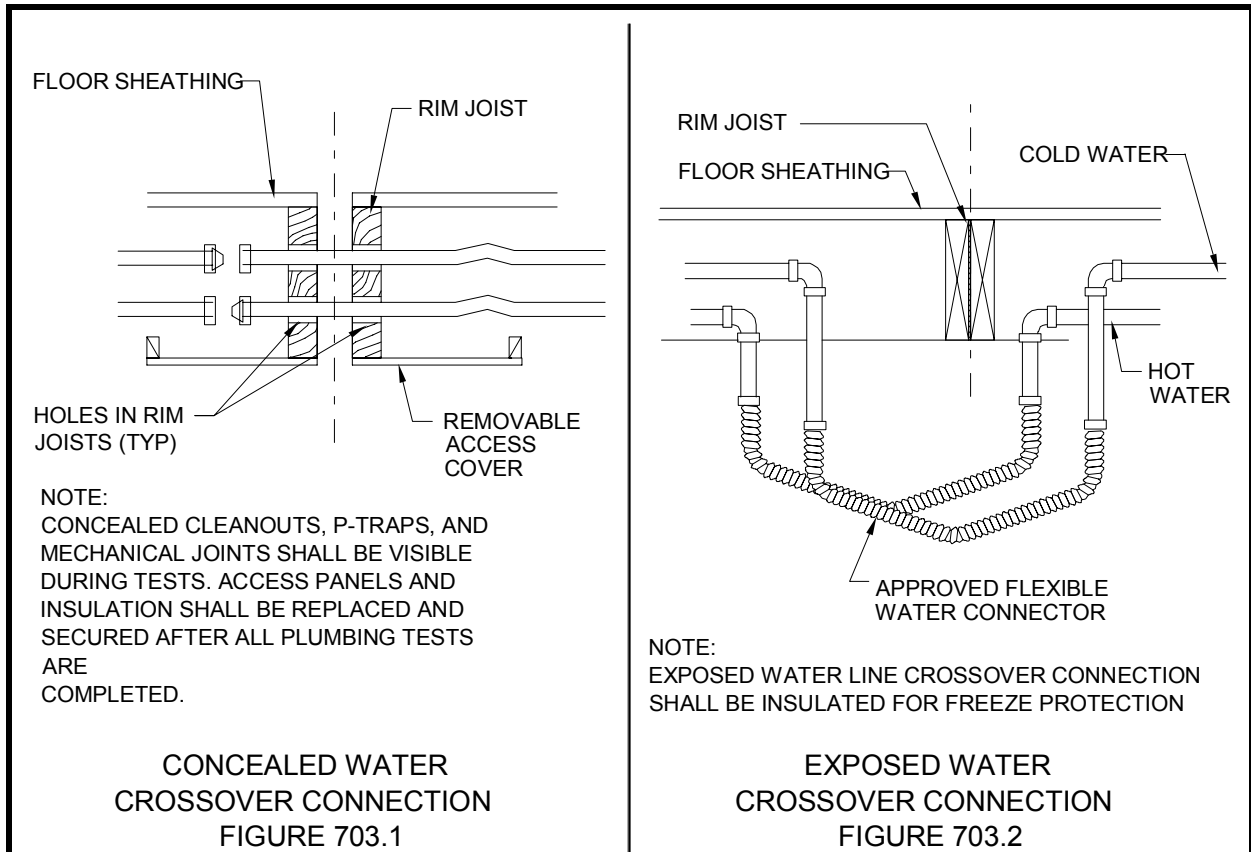

consist of approved pipe and fittings, not less than Schedule 40 and not less in diameter than the pipes being connected.

d. As required by the Idaho State Plumbing Code, site drain plumbing shall be installed as prescribed in the following Subsections. **See Figure 704.1.**

(1) No soil or waste pipe shall be installed or permitted above ground outside of a building or exterior wall.

(2) All drain pipe shall be installed at a grade of one-quarter inch (1/4") per foot except as otherwise permitted by the authority having jurisdiction.

e. As required by the Idaho State Plumbing Code, a full sized clean out extending to or above finished grade, shall be installed at the junction of the building drain and the building sewer. The clean out shall be located approximately two feet (2') from the foundation or skirting. **See Figure 704.1.**

02. Sewer Clean out Access. An accessible sewer clean out shall be located under the manufactured home within the underfloor enclosure.

705. PLUMBING ASSEMBLY.

All plumbing assemblies shall be free from defects, demonstrate acceptable workmanship, and be installed in conformance with acceptable engineering practices and the applicable codes.

Note. The following information is not adopted as part of this standard but is referenced in this standard for the convenience of the user. Users should review the code provisions cited to determine if any changes have been made.

a. As required by the UPC, Section 309, underfloor water and drain plumbing shall meet the following requirements:

(1) Threaded pipe ends shall be reamed and all burrs, chips, cutting oil, and foreign matter removed. Pipe joint compound used on water pipes shall be nontoxic and shall be applied to male threads only;

(2) Pipe joint cement shall be of approved type and applied to male threads only;

(3) Joints and connections in the plumbing system shall be gas-tight and watertight; and

(4) All joints and connections shall be correctly assembled for tightness. Pipe threads shall be fully engaged into the threads of the fitting. Plastic pipe shall be inserted to the full depth of the welding sockets of each fitting. Pipe threads and slip joints shall not be wrapped with string, paper, putty, or similar fillers.

b. As required by 24 CFR 3280.608, water and drain pipe under the manufactured home shall:

(1) Be installed without undue strains and stresses;

(2) Have provisions for expansion contraction and structural settlement;

(3) Be supported or anchored at four foot (4') intervals except for plastic water pipe which shall be secured at thirty-two inch (32") intervals;

(4) Have hangers or anchors of sufficient strength to support the weight of the pipe and its contents; and

(5) Have hangers, clamps, brackets, or anchors which do not compress, distort, cut, or abrade the pipe. Sheet metal or plastic straps (i.e., plumbers tape) may

be used for support as long as the strap is flat against the pipe.

c. As required by the UPC, drainage pipe under the manufactured home shall:

(1) Be installed according to the UPC, using the component parts supplied by the manufacturer;

(2) Be assembled using approved pipe and fittings;

(3) Be installed to provide a one-quarter inch (1/4") per foot grade in all horizontal drain piping. When a full size clean out is installed at the upper end, the grade may be reduced to one-eighth inch (1/8") per foot;

(4) Have clean outs located so a cleaning tool does not have to pass through more than 135 degrees of fittings excluding removable traps;

(5) Have clean outs installed so they open opposite of the flow, or at right angles to the pipe;

(6) Be not less in diameter than the pipe it is being connected to;

(7) Use approved fitting for all changes in direction;

(8) Use 45 degree "Y" branches, 60 degree "Y" branches, long turn "TY" branches, sanitary "T" branches, or other approved fittings or combination of fittings having equivalent sweep for all horizontal to vertical drain pipe connections; and

(9) Use 45 degree "Y" branches, long-turn "TY" branches, or other approved fittings or combination of fittings having equivalent sweep for all horizontal to horizontal and vertical to horizontal drain pipe connections;

d. As per 24 CFR 3280.606, the following shall be provided for manufactured home water and drain plumbing:

(1) An unobstructed minimum clearance of twelve inches (12") in front of each clean out opening;

(2) An access panel for each trap which has mechanical joints and is located inside a floor or wall;

(3) Accessibility to all water and drain crossover connections;

e. All access panels in walls and floors shall be insulated and shall be secured in place after all plumbing tests are complete.

f. As per 24 CFR 3280.603(6), the following are prohibited:

(1) Drilling or cutting holes in drain or vent piping;

(2) Using vent pipes as waste or drain pipes except as provided by the manufacturer's original design;

(3) Using fittings which retard the flow of sewage or air;

(4) Patching or concealing cracked or imperfect pipe rather than replacing it; and

(5) Bending rigid piping rather than installing directional fittings.

706. PLUMBING TESTS.

01. **Water Test.** The water distribution system of the manufactured home and the supply connection shall be tested to assure there is no leakage under normal operating pressure.

02. **Drain Test.** The manufactured home drainage piping system shall be connected to the site sewer inlet, and tested by allowing

water to flow into all fixtures and receptors, including the clothing washer standpipe, for a period of three (3) minutes. If water under pressure is not available, the drainage piping system shall be tested by letting at least three (3) gallons of water into each fixture and receptor. Each P-trap and clean out shall be visible during this test to assure there are no leaks.

707. -- 799. RESERVED.

Chapter 8 MECHANICAL CONNECTIONS

801. GENERAL.

01. **Permits.** A separate permit is not required for the installation of heat duct crossovers or appliance exhaust ducts. This work is covered by the manufactured home installation permit. A separate permit may be required by local ordinances for alterations and all field installations of air conditioners, heat pumps, and fuel burning appliances.

02. **Installations.** All mechanical installations in connection with the alteration, repair, conversion of, or addition to, a manufactured home shall comply with the appropriate mechanical code as adopted by local authority having jurisdiction and this standard.

802. MECHANICAL EQUIPMENT.

01. **Original Installations.** Mechanical connections designed for the manufactured home by the manufacturer shall be installed to the manufacturer's installation instructions. Heat pumps or air conditioners added to a home during, or prior to, the initial sale to the first consumer shall be listed for manufactured home or mobile home use and shall be listed for use with any manufactured home heating or air handling equipment it is used in conjunction with.

02. **After Market Installations.** Mechanical installations not a part of the original manufactured home shall be in conformance with the appropriate mechanical code as adopted by the local authority having jurisdiction and installed according to their listings. It is highly recommended that heat pumps, air conditioners, water heaters, and furnaces installed in a manufactured home after

the initial sale to the first consumer be listed for manufactured or mobile home use.

03. **Equipment Support.** Mechanical equipment installed outside of, and not supported by, the manufactured home shall be mounted on a minimum three inches (3") thick level concrete slab, precast reinforced concrete slab, or a listed mounting base. The equipment shall be mounted according to the applicable equipment manufacturer's installation instructions. The top surface of the slab or base shall be a minimum of two inches (2") above the finished grade. **See Figure 802.1.**

04. **Prohibited Installations.** Mechanical equipment shall not be installed in any required egress window or obstruct any egress from the home.

05. **Condensation Drains.** Condensation drains from air conditioners, pumps, evaporative coolers, dehumidifiers, refrigeration equipment, or any other appliance shall not terminate under a manufactured home and shall deliver drained liquids away from the home.

803. CROSSOVER DUCTS.

01. **General.** All parts of the heating and cooling ducts system which are connected on the site shall be installed to be mechanically secure, protected from ground moisture and water, sealed with durable materials installed per the duct manufacturer's instructions, and insulated to R-8 minimum in all new homes manufactured after January 1, 2002. This includes crossover ducts, extensions, elbows, splitter boxes, and all other components.

02. **Crossover Ducts.** Heat crossover ducts shall be made of the following material and

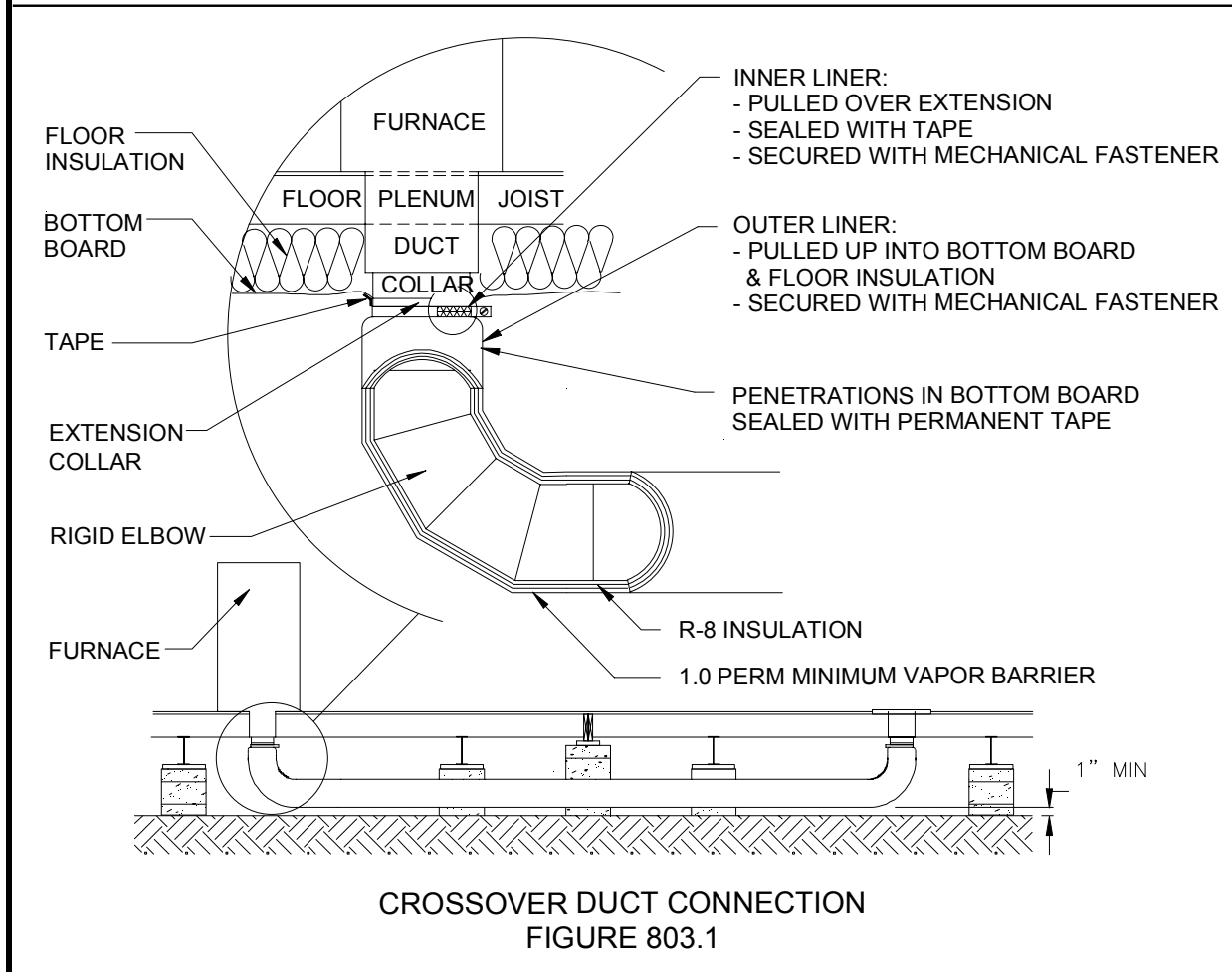
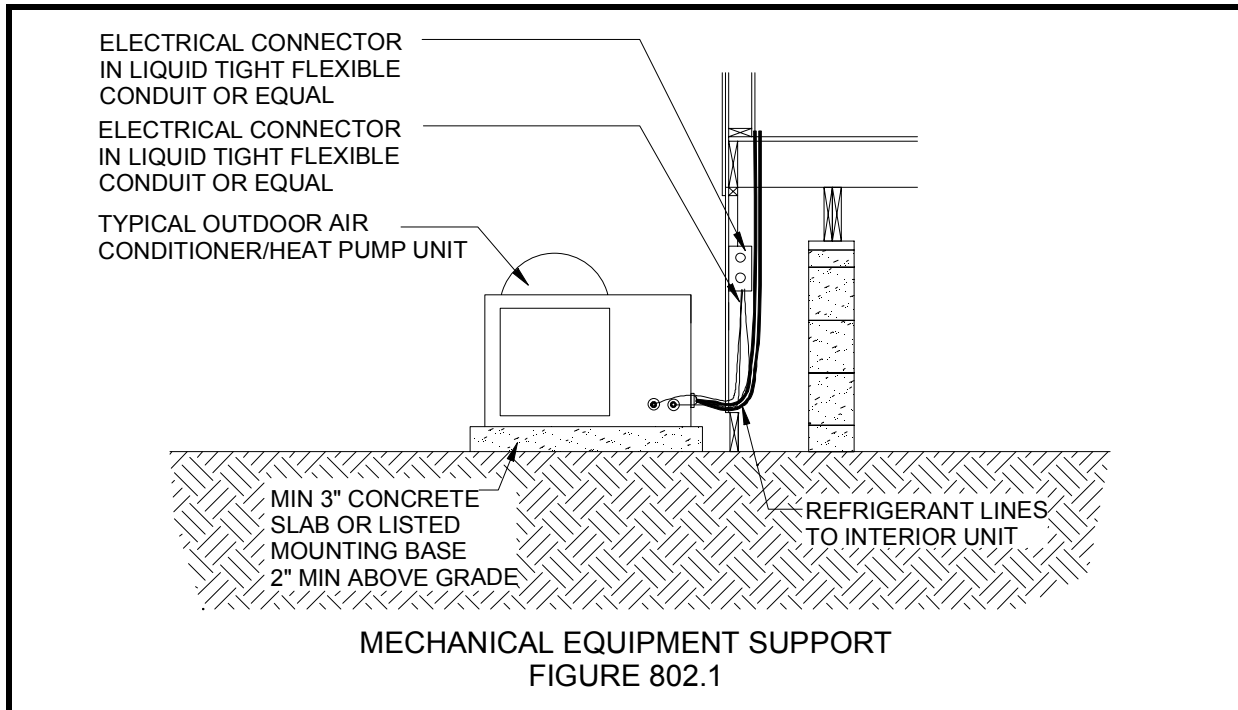

installed according to the following requirements. **See Figure 803.1.**

a. Crossover ducts on new homes manufactured after January 1, 2002 shall have a minimum of R-8 insulation, a vapor retarder rated at one (1.0) perm or less, an inner liner of spring steel wire helix banded within two (2) layers of 57 gauge Mylar polyester film or equal and an interior diameter not less than that of the plenum collars.

b. Crossover ducts shall be designed and installed to eliminate pressure of the bottom board and floor insulation against the connection. Common practice includes adding an extension and elbow to the collar. Where such extensions and elbows are used they shall be a minimum 26 gauge metal, connected to the collar with at least three (3) sheet metal screws, and sealed at the collar connection with minimum two inch (2") wide foil tape (Nashua #322 or Hardcast AFG 1402 or equivalent) or duct sealer for outdoor application (RCD #6 or equivalent) installed per the manufacturer's specifications. If jointed elbows are used; the joints shall be sealed in the same manner as the collar connection. A rigid 90 degree elbow shall be used on new homes manufactured after January 1, 2002 to connect the crossover duct to the main supply duct collar.

c. Where an extension or elbow is used, the inner liner, shall be cut back leaving sufficient outer liner, insulation, and vapor retarder to cover the extension or elbow. The outer liner, R-8 insulation, and vapor retarder shall cover the extension or elbow (**See Figure 803.1**), and shall extend up into the floor insulation and bottom board and be taped to the bottom board where

the crossover duct enters with approved bottom board tape.

d. The inner liner, along with the wire helix, of the crossover duct shall be extended over, and be secured to, the sheet metal extensions, elbows, or collars with at least three sheet metal screws placed to securely hold the wire helix. Alternatively, a tool tightened plastic cable tie strap ("Panduit" strap or equivalent) may be used where a lip on the extension, elbow or collar will prevent the strap from slipping off. Where screws are used, the tears shall be repaired with foil or Mylar tape. The joint shall be sealed with minimum two inch (2") wide foil tape (Nashua #322 or Hardcast AFG 1402 or equivalent) or with a duct sealer rated for outdoor applications (RCD #6 or equivalent). The tape or sealer shall be installed per the manufacturer's specifications. The outer liner and insulation shall be returned back to cover the inner liner and the extension, elbow, or collar, and shall be secured in place with a mechanical fastener.

e. Adequate clearance shall be maintained under the manufactured home for the heating and cooling duct crossovers. Crossover ducts shall be blocked or suspended above the ground providing one inch (1") minimum clearance. If blocks are used, they shall be pressure treated wood, concrete, or extruded polystyrene insulation board.

f. Crossover ducts shall be installed with a minimum of bends and length which restrict air flow, shall be adequately supported, and not be crushed, dented, compressed, or have sharp bends or stress at the connections. All tears or holes in the inner liner shall be sealed with sealer specified in **Subsection 803.02.d.** and the

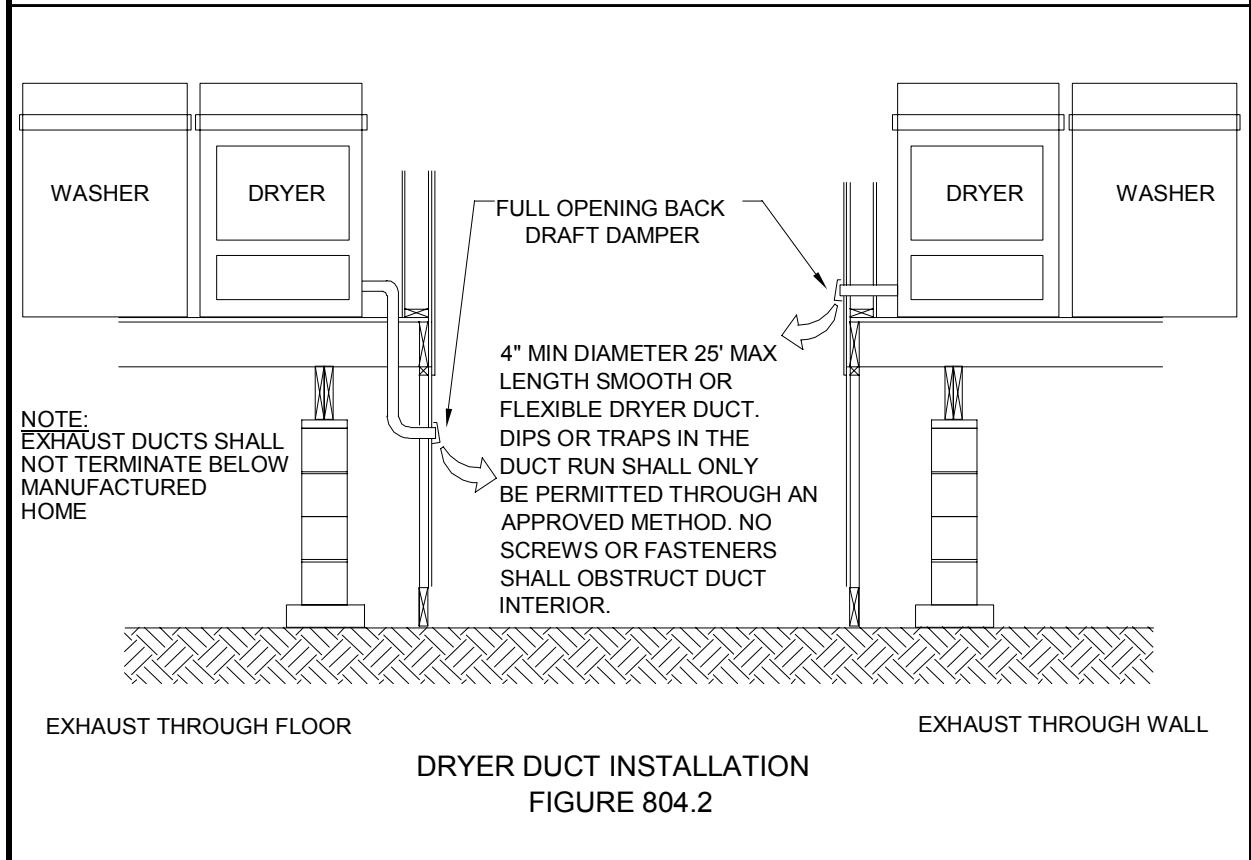
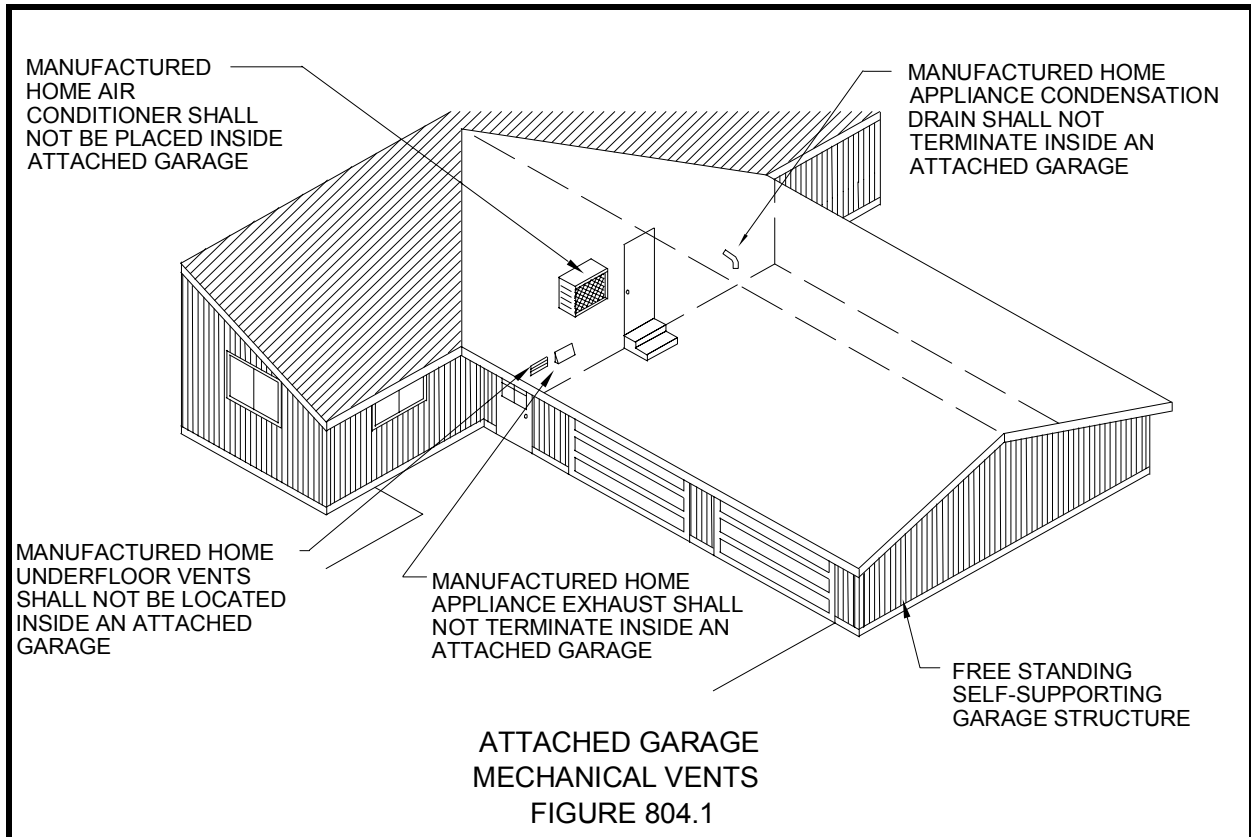

outer liner shall be repaired with bottom board sealer.

804. APPLIANCE VENTING.

01. Venting. Appliance venting shall comply with the appliance manufacturer's installation instructions and the following requirements:

a. Moisture or heat producing appliances, such as dryers, shall be vented to the outside atmosphere in a manner to ensure moisture laden air is carried out beyond the perimeter of the home. Listed nonventing appliances are not required to have external vents.

b. Exhaust ducts shall be routed through the wall, floor, skirting, or foundation, to the exterior. Exhaust duct systems of clothes dryers, ranges, or other appliances shall not terminate beneath the manufactured home. Exhaust duct installations shall, whenever possible have no dips or traps and shall be installed according to the applicable appliance manufacturer's installation instructions.

c. No inlets or outlets of an exhaust vent, combustion air vent, or return air vent capable of conveying air, liquid, or gasses into or out of any appliance shall be located under the manufactured home when it is installed over a basement, or in an area where a garage is to be attached.

See Figure 804.1.

02. Dryer Exhaust Vents. Dryer exhaust ducts, when required, shall be installed according to the dryer manufacturer's installation instructions or as prescribed in the following Subsections. **See Figure 804.2.**

a. The duct shall be a minimum of four inches (4") in diameter and no longer than twenty-five feet (25'). The total length

shall be reduced five feet (5') for each ninety (90) degree turn.

b. The duct material shall be rigid metal, rigid PVC, or flexible metal.

c. Nonmetallic duct or flexible foil duct material shall not be used within three feet (3') of the dryer connection or enclosed within a wall or floor cavity;

d. No screws, fasteners, screens, or other obstructions, shall extend into the duct.

805. -- 899. RESERVED:

This page intentionally blank.

Chapter 9
ACCESSORY BUILDINGS AND STRUCTURES

901. GENERAL.

01. **Standards.** Every manufactured home accessory building or structure shall be designed and constructed according to the applicable locally adopted Building Codes and this standard. Permits must be obtained prior to construction.

902. UNDERFLOOR ENCLOSURES.

01. **Requirement.** Each manufactured home shall have the underfloor crawl space entirely enclosed with a permanent foundation or approved skirting material. The permanent foundation or skirting material shall be installed at the time the home is set.

02. **Skirting.** Skirting shall conform with the requirements in the following Subsections. See **Figures 902.1** and **902.2**.

- a. Skirting shall be constructed of a durable rigid material such as vinyl, wood, aluminum, or steel, and shall be suitable for exterior exposure. Untreated wood shall not be utilized within six inches (6") of any earthen material.
- b. Skirting shall be installed according to the skirting manufacturer's installation instructions and this subsection.
- c. Skirting shall be adequately secured to assure stability, to minimize vibration, and to minimize susceptibility to wind damage.
- d. Skirting shall be installed to compensate for possible frost heave.
- e. Holes or gaps between the skirting and the ground, or any other gap anywhere around the skirting that could permit

rodents to get under the home, shall be sealed or back filled.

f. Skirting shall not be attached to a manufactured home in a manner which will permit water to be trapped between the skirting and the siding or between the skirting and the trim of the manufactured home.

g. All framing used to secure skirting material and located within six inches (6") of earth shall be pressure treated lumber.

h. Deck, porch, or landing floors which are not insulated and which allow for the free flow of air and moisture through them shall be separated from the underfloor area of a manufactured home by skirting, a foundation, or a durable flexible material such as sheet vinyl, Plexiglas, Fiberglass, ABS, or EPDM. The area below an open floor may be enclosed with lattice work, skirting, or a foundation wall if made accessible according to **Section 904** of this standard. See **Figure 902.2**. See **Subsection 302.06.f.** for vapor retarder installation at this location. Vents shall be installed as prescribed in Section 903.

03. **Perimeter Foundations.** Perimeter permanent foundation walls of wood, concrete, or concrete block supporting the exterior walls of the manufactured home shall be designed and constructed according to Section 305.

903. UNDERFLOOR VENTILATION.

01. **Requirement.** All manufactured homes shall be provided with underfloor ventilation meeting the requirements prescribed in the following Subsections.

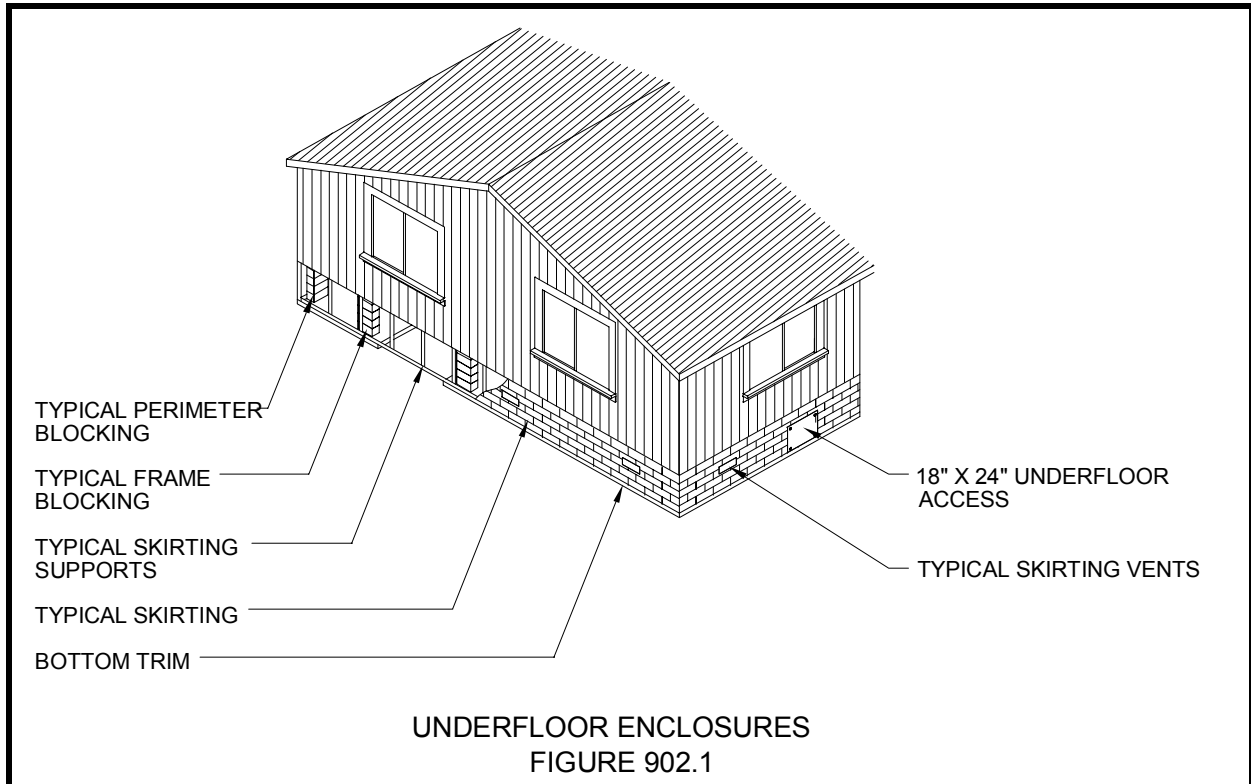

NOTE:
PERIMETER PIERS AND TIE DOWNS
UNDER THE RECESSED PORCH
ARE NOT SHOWN
FOR CLARITY
ONLY

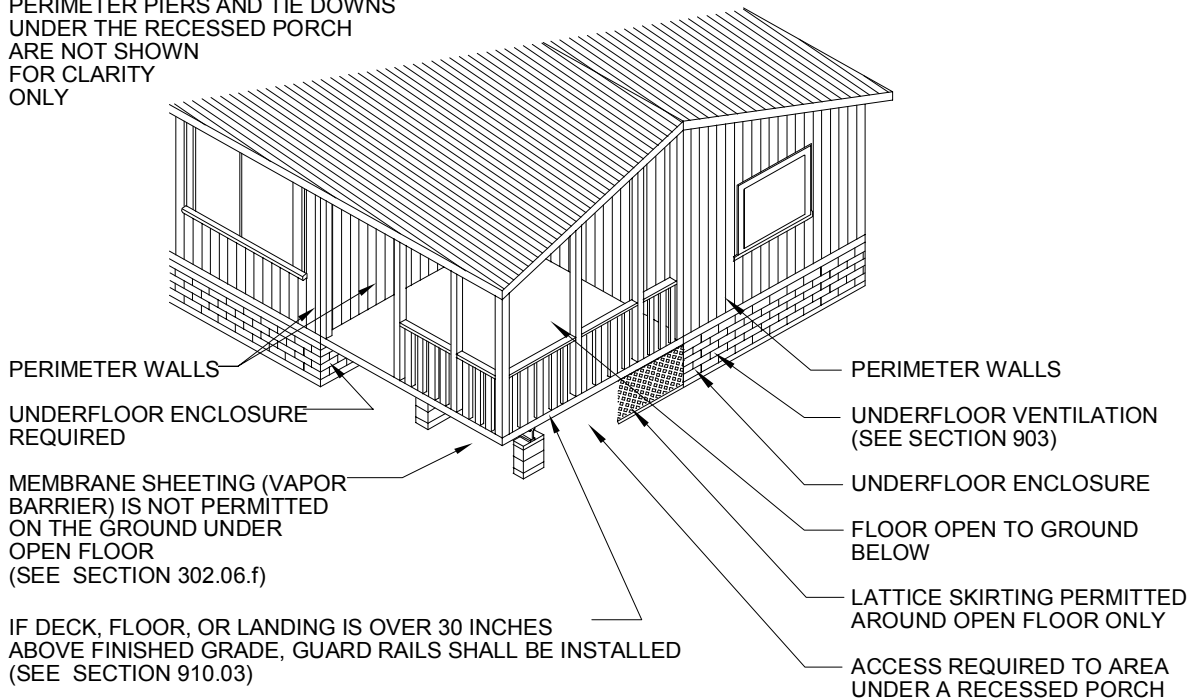

- a. A minimum of eight ventilation openings shall be provided from the underfloor space to the exterior.
- b. A ventilation opening shall be placed three feet (3') from each corner, or as near to three feet (3') from each corner as practical. Vents shall not be spaced more than twenty feet (20') apart. Vents shall be placed as high as practical.
- c. The total net free area for ventilation shall be one square foot for every three hundred (300) square feet of underfloor area.
- d. Ventilation openings shall provide ventilation on at least three sides of the manufactured home.
- e. Ventilation openings shall be provided with one-quarter inch (1/4") corrosion resistant wire mesh or with louvered openings with not less than one-eighth inch (1/8") screen to retard the entry of vegetation, waste materials, and rodents.
- f. When a vent label does not include a rating of the net free area, the free area may be calculated by deducting twenty-five percent (25%) from the gross ventilation area. This calculation adjusts for blockage caused by vent hardware such as screens and louvers. The gross vent area is calculated by the length times height of the opening through the vent.
- g. Intake air for indoor ventilation purposes, except for combustion air, shall not be drawn from underfloor spaces of the manufactured home.
- h. When combustion air for heat producing appliances is taken from the underfloor area, ventilation shall be adequate to assure proper operation of the

appliances. No increase in the minimum underfloor ventilation is necessary.

- i. When a manufactured home is placed over a basement and the combustion air for heat producing appliances is designed to be taken from the underfloor area, the combustion air inlets shall be ducted to the outside of the basement area.

904. UNDERFLOOR ACCESS.

01. Requirement. All manufactured homes shall be provided with an access to the underfloor area through one of the methods described in this section.

02. Skirting Access. Underfloor access through the skirting shall:

- a. Have a minimum clear opening of eighteen inches high by twenty-four inches wide (18"x24");
- b. Require no tools, no more than five (5) pounds of force, nor the operation of more than four devices, to open;
- c. Be easily identifiable;
- d. Have a minimum thirty inch (30") clear space directly in front, outside the perimeter of the home, of each access panel or door.

03. Foundations and Ground Level Access. Ground level installations shall be provided with an access well which shall conform to the following requirements.

- a. The access well shall have a minimum inside dimension of twenty-four inches (24") high by thirty-six inches (36") wide, and extend at least twenty-four inches (24") from the perimeter of the home.
- b. The access well shall have a minimum clear opening of eighteen inches high by

twenty-four inches wide (18"x24") to the underside of the home.

c. The access well shall have a lightweight removable watertight cover made to resist the entrance of animals or water. The cover shall be designed and installed so that it cannot be locked. The cover shall be designed and installed so that it can be easily opened without using any tools.

04. **Floor Access.** Access openings through the floor of a manufactured home shall be provided only by the manufacturer and constructed according to approved Design Approval Primary Inspection Agency (DAPIA) plans. For other approvals see **Subsection 201.02.**

05. **Stairway Access.** Access openings through the manufactured home floor for stairways shall be provided only by the manufacturer and constructed according to approved DAPIA plans. For other approvals see **Subsection 201.02.**

905. CARPORTS & AWNINGS.

01. **Accessories.** Permanent awnings or carports shall be erected or constructed on a manufactured home site only as an accessory to a manufactured home located on the same site. This section of the standard does not apply to temporary, flexible, or fabric awnings and carports, nor to fixed window awnings used with manufactured homes.

02. **Site Built.** Permanent or rigid awnings or carports shall be constructed, supported, attached, and anchored according to locally adopted building codes and this standard.

03. **Prefabricated.** Approved prefabricated awnings and carports shall be installed, attached to the manufactured home and anchored into the ground according to methods

prescribed in the awning or carport manufacturer's installation instructions.

04. **Windows and Doors.** Manufactured home windows and doors may open directly into a space occupied by a permanent or rigid awning or carport.

05. **Enclosure.** Permanent awnings or carports shall not be enclosed with rigid materials or walls or converted for use as a habitable room or garage unless the completed construction complies with all the requirements of the local codes and this standard. Enclosing the awning or carport shall not take the manufactured home out of conformance with any state or federal manufactured home regulation.

a. **Exception:** Awnings may be enclosed with insect screening if required egress paths are not blocked. See **Section 909.**

06. **Wall Support.** When a prefabricated awning or carport is attached to and supported by the wall of a standard set manufactured home, supports complying with **Section 304** of this standard shall be placed under the exterior wall. The supports shall be spaced a maximum of four feet (4') on center under the area of attachment. A perimeter support foundation meets this requirement.

07. **Wall Attachment.** A site built permanent awning or carport may be attached to an exterior wall of a manufactured home to improve its stability. In that case the awning or carport shall be supported by a horizontal rail a minimum of two inches by six inches (2" x 6") nominal size attached with a minimum of two (2) three and one-half inch (3 1/2") long (16d) nails or equal having a minimum one and one-half inch (1-1/2") penetration into each exterior wall stud in the area of attachment. Under no condition shall horizontal rails be secured into or supported by the manufactured home exterior wall top plates. Additional

support posts shall be added under this horizontal rail to assure the carport or awning is self supporting. **See Figure 905.1.**

08. Roof Support. A prefabricated awning or carport may only be attached to manufactured home roof trusses, eaves, or fascia, according to engineered DAPIA approved plans demonstrating the manufactured home roof was engineered and constructed to carry the additional loads. DAPIA approved plans shall be made available to the authority having jurisdiction before the installer or homeowner will be permitted to attach an awning or carport to a manufactured home truss, eaves, or fascia.

906. PORCHES.

01. Accessory. A porch may be installed or constructed on a manufactured home site only as an accessory to a manufactured home on the same site.

02. Self Supportive. A porch shall be designed and constructed as a self supporting structure but may be attached to a manufactured home to provide a weather seal. **See Figure 906.1.** If both the home and the porch are on a permanent foundation, the roof may be attached to the home per **Subsection 905.07.**

03. Code. Porches shall be designed and constructed to the requirements of the locally adopted building code.

907. ATTACHED GARAGES.

01. Accessory. An attached garage shall be constructed on a manufactured home site only as an accessory to a manufactured home on the same site.

02. Self Supportive. A garage attached to a standard set manufactured home shall be designed and constructed as a freestanding, self supporting structure and may only be attached

to a manufactured home to provide a weather seal. If both the home and garage are on a permanent foundation, the garage may be attached to the home but must remain self supporting. A dormer may be constructed to the manufactured home roof to provide this attachment. **See Figure 907.1.**

03. Code. Attached garages shall be designed and constructed according to locally adopted building codes and this section.

04. Separation. Attached garages shall be separated from the manufactured home according to the requirements prescribed in the following Subsections. **See Figure 907.1.**

a. No opening shall be permitted from a garage directly into a room used for sleeping purposes. No windows shall be permitted in the exterior wall of a manufactured home where a garage is to be attached. Any opening between the garage and manufactured home shall be equipped with a twenty (20) minute fire rated door of solid wood not less than one and three-eighths inches (1-3/8") in thickness, or the equivalent;

b. The garage shall be completely separated from the manufactured home, including attic and crawl space areas, with a minimum five-eighths inch (5/8") fire rated gypsum board or its equivalent;

c. Exhaust vent, combustion air vent, return air vent, condensation drain, or any other vent or opening capable of conveying air, moisture, liquid, or gasses into or out of the manufactured home, or to or from any appliance used in conjunction with the manufactured home, shall not be located in an area where a garage is intended to be attached.

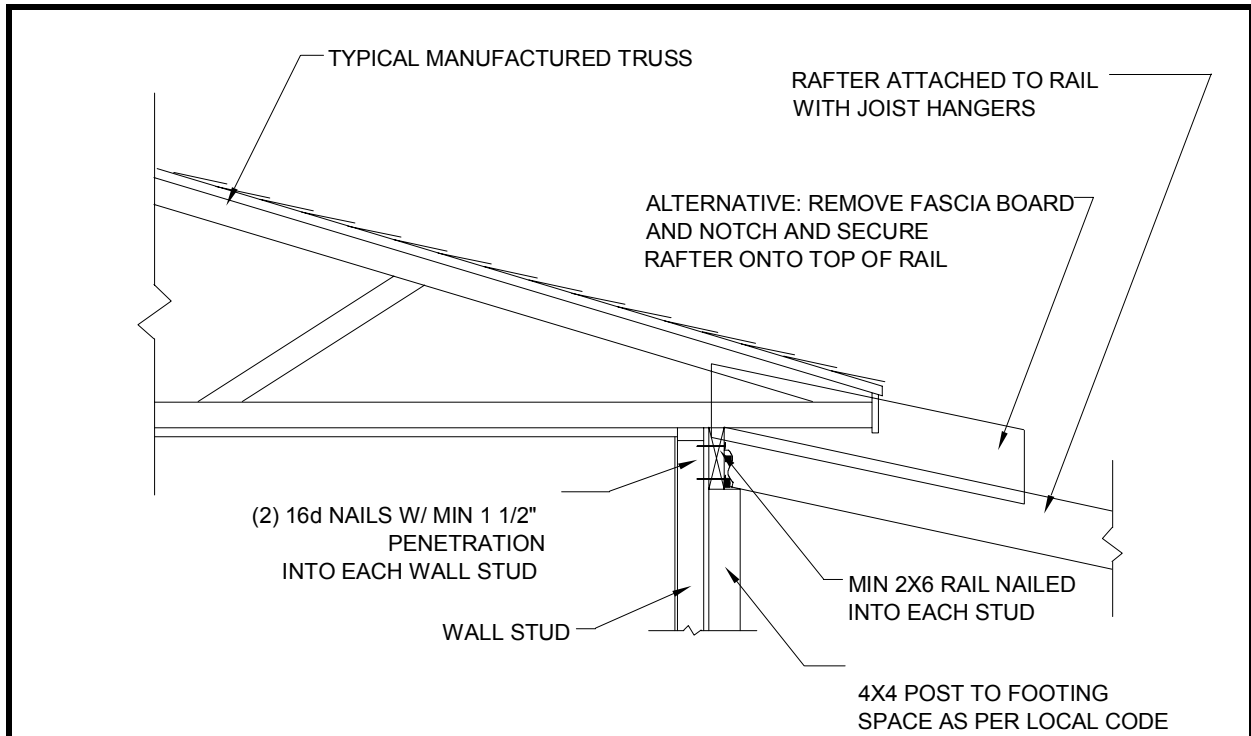

CARPORT CONNECTION
FIGURE 905.1

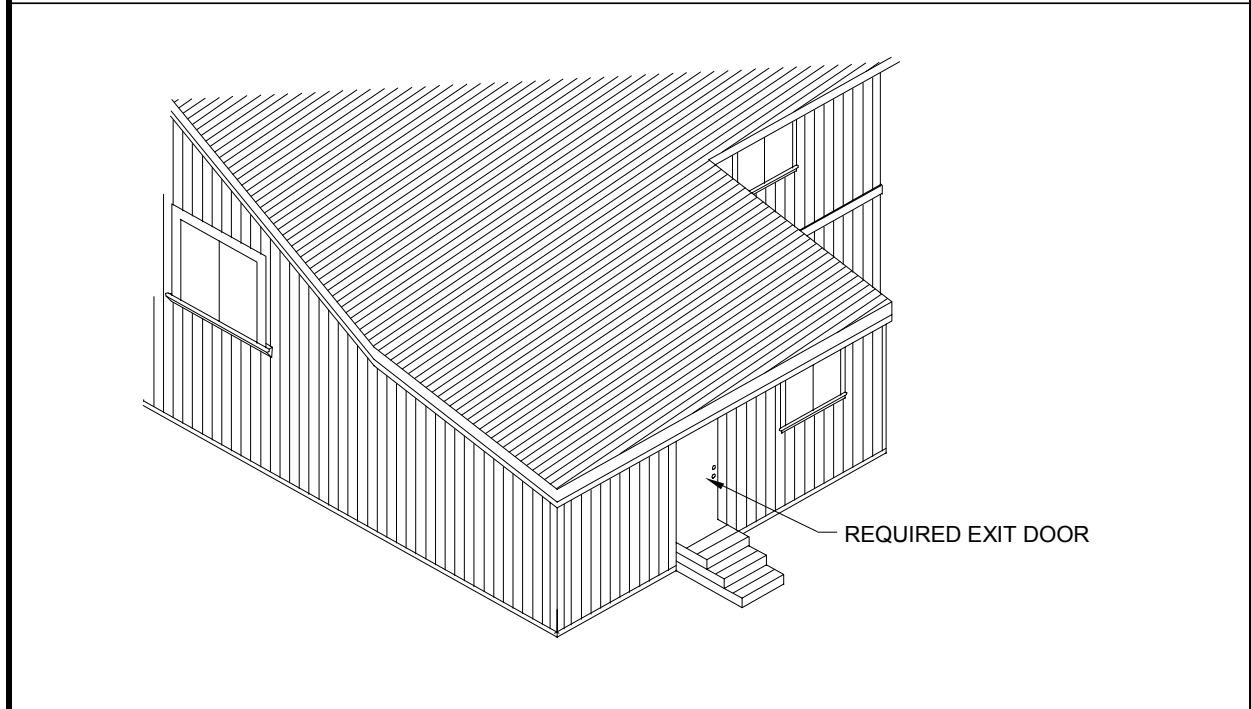

PORCH INSTALLATION
FIGURE 906.1

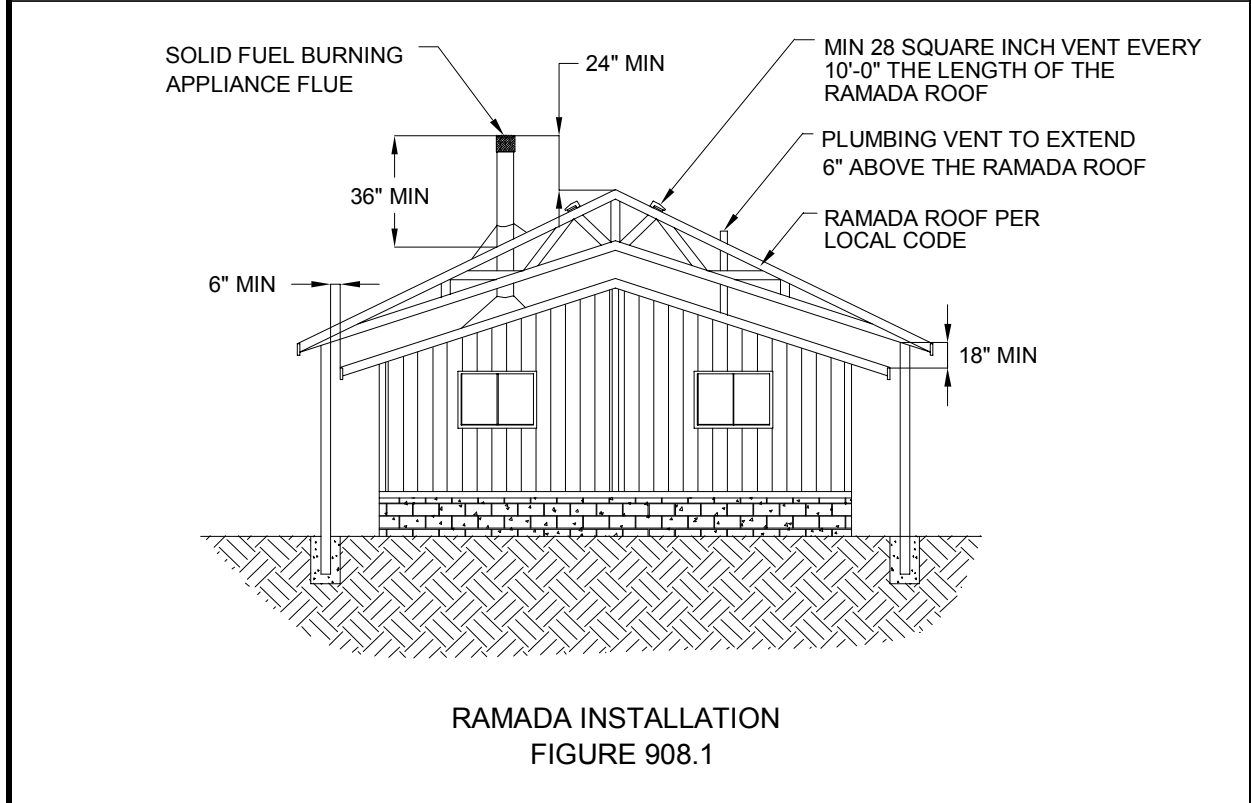
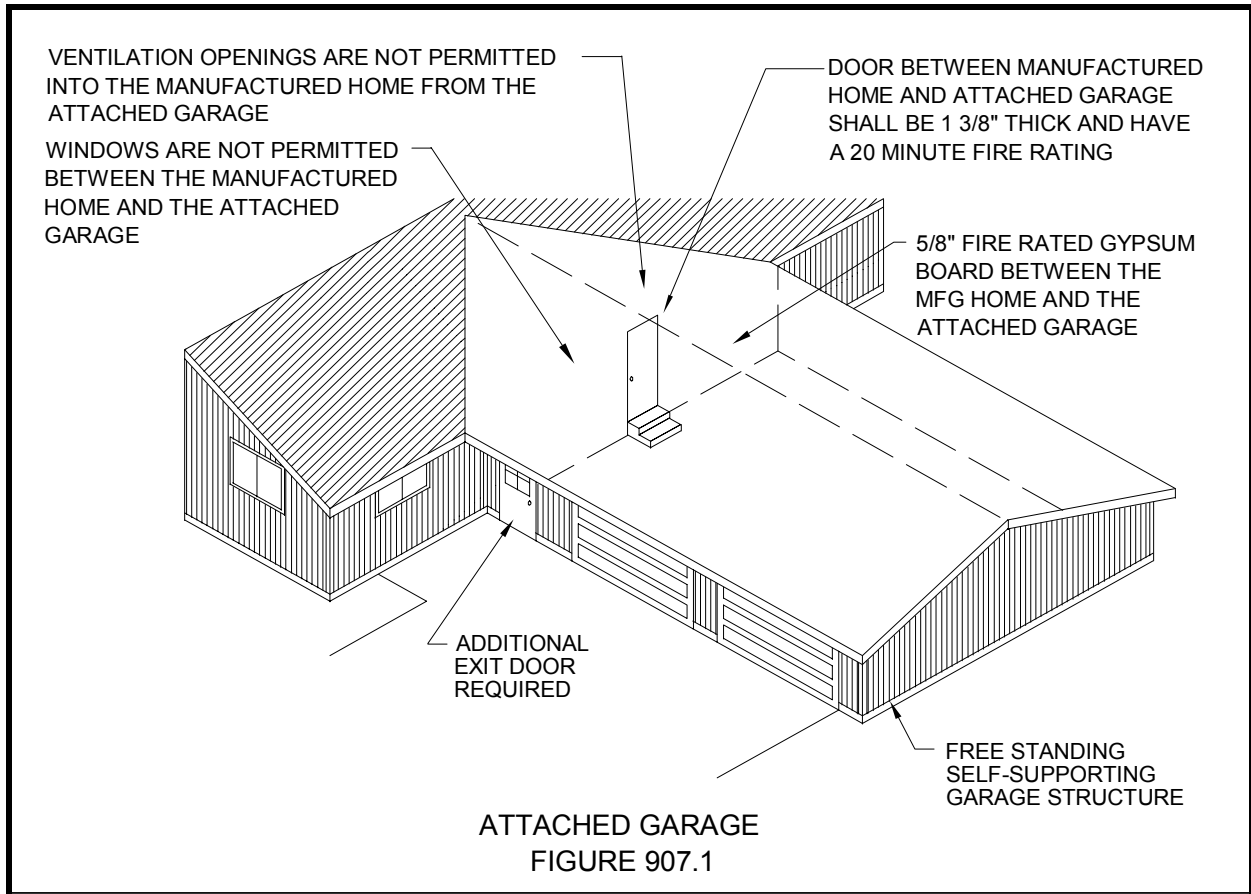

908. RAMADAS.

01. **Accessory.** A ramada shall be erected, constructed or maintained on a manufactured home site only as an accessory to a manufactured home located on the same site.

02. **Clearance.** A ramada or any portion thereof shall have a clearance of not less than eighteen inches (18") in a vertical direction above the highest portion of a manufactured home roof and not less than six inches (6") in a horizontal direction from each side of a manufactured home. **See Figure 908.1.**

03. **Self Supportive.** A ramada shall be designed and constructed as a freestanding, self supporting structure meeting the requirements of the locally adopted building code.

04. **Enclosures.** A ramada shall not be wholly enclosed on any side or end. Gable ends must be vented if they are enclosed.

05. **Chimneys and Flues.** Manufactured home chimneys, flues and vents shall be extended through the ramada roof as prescribed in the following Subsections. **See Figure 908.1.**

a. Chimneys or flues from solid fuel burning appliances shall extend at least three feet (3') above the part of the ramada roof through which it passes and at least two feet (2') above the highest elevation of any part of the ramada roof within ten feet (10') horizontal of the chimney.

b. Vents for fuel burning appliances shall extend through the ramada roof according to the listing of the appliance.

c. Plumbing vents shall extend through the ramada roof a minimum of six inches (6") above the flashing. Plumbing vents shall not be located within three feet (3') of any motor driven air intake that opens into habitable rooms.

06. **Egress and Exit.** Egress doors and windows may exit out of a manufactured home covered by a ramada provided there are no obstructions in the path of egress to the area outside the ramada.

909. ACCESS & EGRESS.

01. **Requirement.** There shall be a minimum of two exit doors in each manufactured home. Each bedroom shall have one emergency egress window providing access to the outside.

02. **Obstructions.** Accessory buildings or structures shall not obstruct a required exit, egress window, appliance access, or utility access except where specifically permitted in this standard. No hinged exterior egress door shall be prevented from opening at least 90 degrees. Door locks or other obstructions which would obstruct the path of egress from a manufactured home shall not be installed nor be permitted to remain

03. **Enclosed Exit Doors.** When an accessory building or structure, other than an awning or carport, encloses an exit door of the manufactured home so that it no longer provides egress to the outside an additional exit door, opening to the outside, shall be installed in either the manufactured home (**See Subsection 201.02**) or the accessory building or structure. This new door must be located in close proximity to the original door.

04. **Original Exit Door.** One of the original manufactured home exit doors must open directly to the outside without passing through an accessory building or structure.

a. **Exception:** Egress may open directly into and pass through a carport as described in **Section 905** of this standard.

05. Prohibited Construction. No accessory building or structure shall be constructed which obstructs any required means of egress from a manufactured home.

910. DECKS, PORCHES, LANDINGS, STAIRS, RAMPS & GUARDRAILS.

01. Construction Standard. Every porch, deck, landing, stair, ramp, guard rail, or guardrail erected, constructed, or maintained adjacent to a manufactured home shall comply with the locally adopted building code.

02. Attachment to Manufactured Home. When a deck, landing, ramp, or stairs is attached to the wall of a conventionally set manufactured home, supports complying with **Section 304** of this standard shall be placed under the exterior wall at a maximum spacing of four feet (4') on center under the full length of the area of attachment.

03. Required Installations. If during the installation of a manufactured home, a porch, deck, or landing (recessed porch) constructed by the manufactured home manufacturer is over thirty inches (30") above the finished grade, it shall have guardrails installed conforming to the locally adopted building code.

911. -- 999. RESERVED.

This page intentionally blank

Chapter 10 HEAT PRODUCING APPLIANCES

1001. GENERAL.

01. **Listing Requirement.** All fuel burning appliances and equipment shall be listed for their intended use, and all solid fuel burning appliances and equipment shall be listed for manufactured home or mobile home use.

02. **Installation Instructions.** Installation instructions shall be provided with each heat producing appliance and made available to the authority having jurisdiction during inspections.

03. **Derating Appliances.** All gas and oil fuel burning appliances and equipment in homes that are installed at an elevation greater than two thousand feet (2000') above sea level shall be derated according to the utility company requirements and appliance and equipment manufacturer's specifications. All required adjustments and modifications shall be performed by authorized service technicians who shall provide documentation of the derating to the inspecting authority.

04. **Accessibility.** All fuel burning appliances shall be accessible for inspection, service, repair, or replacement without removing permanent construction.

05. **Clearance.** Flue gas outlets and exhaust vents shall terminate not less than three feet (3') distant from any motor driven air intake discharging into habitable areas.

06. **Other Appliances.** Heat producing appliances not specifically mentioned in this standard shall, at a minimum, be listed and approved for use in manufactured homes and shall be installed according to the listing and the appliance manufacturer's installation instructions.

07. **Operating Instructions.** Operating instructions shall be provided to the homeowner with each heat producing appliance installed.

1002. RANGES & DRYERS.

01. **Listed Standards.** Fuel burning cooking range and clothes dryer appliances shall be listed for their intended use. Replacement fuel burning range and dryer appliances are not required, but are recommended, to be listed for manufactured home or mobile home use. However, they must be, at a minimum, installed according to their listings and the appliance manufacturer's installation instructions. Electric cooking range and clothes dryer appliances shall be listed for manufactured home or mobile home use or shall be manufactured so that the neutral conductor is insulated from the grounding conductor and the equipment enclosure.

02. **Clearances.** Ranges shall be installed so that there is a minimum vertical clearance of twenty-four inches (24") above the cooking top.

03. **Dryer Exhaust.** Dryer appliances shall exhaust directly to the outside of the manufactured home and shall not terminate beneath manufactured homes nor into any confined space. Listed nonventing dryers are not required to have an external vent.

04. **Range Exhaust Vents.** Range and cook-top appliances equipped with integral exhaust vents shall exhaust directly to the outside of the manufactured home according, at a minimum, to the appliance manufacturer's installation instructions, and shall not terminate

beneath the manufactured home or in a confined space.

1003. FURNACES, GAS STOVES, WATER HEATERS, & GAS FIREPLACES.

01. Appliance Listing. Fuel (gas or oil) burning and electric furnace and water heater appliances shall be listed for their intended use. Replacement fuel burning and electric furnace or water heater appliances are not required (but are recommended) to be listed for manufactured home or mobile home use but must, at a minimum, be installed according to their listings, the appliance manufacturer's installation instructions, and this section of this standard.

02. Installation. Fuel (gas or oil) burning furnaces, stoves, fireplaces, and water heater appliances shall be installed to provide for the complete separation of the combustion system from the interior atmosphere of the manufactured home. **See Figure 1004.1.** This separation shall be accomplished by one or both of the following two methods.

a. Install a direct vent system (sealed combustion system) listed or certified as components of the appliance.

b. Install the appliance within an enclosure accessible only from outside the manufactured home so as to separate the appliance combustion and venting systems from the interior atmosphere of the manufactured home. There shall not be any door, removable access panel, or other opening into the enclosure from the inside of the manufactured home. Any openings or penetrations for ducts, return air inlets, piping, or wiring shall be sealed.

03. Combustion Air. Combustion air shall not be taken from within any wall cavity, floor cavity, or ceiling cavity, or from a basement area. Combustion air may be taken from a

ventilated crawl space below the manufactured home.

04. Flue Listing. Flue gas outlets shall be listed or certified as components of the appliance and installed, at a minimum, according to the listing and the appliance manufacturer's installation instructions.

05. Appliance Compartment. All furnace and water heater appliance compartments shall have the interior walls, door and ceiling lined with minimum three-eighths inch (3/8") thick gypsum board or equivalent material having a maximum flame spread rating of twenty-five (25).

06. Securement. All furnace and water heater appliances shall be secured in place to prevent movement.

1004. SOLID FUEL BURNING FIREPLACES & STOVES.

01. Listing Standard. Solid fuel burning factory built fireplaces and stoves listed for use in manufactured homes or mobile homes may be installed in manufactured homes provided their installation conforms with this standard.

02. Minimum Stove Construction Requirements. Solid fuel burning fireplaces and stoves shall:

a. Be constructed to the Department of Housing and Urban Development Manufactured Home Construction and Safety Standards 24 CFR 3280.709;

b. Be equipped with integral door(s) or shutters designed to close the fireplace or stove fire chamber opening;

c. Be equipped with a combustion air inlet designed to conduct air directly into the fire chamber and prevent material from the hearth dropping onto the area beneath the manufactured home;

- d. Have a complete means for venting through the roof;
- e. Have a hearth extension; and
- f. Have a means to secure the fireplace or stove to the floor.

03. **Labeling.** The label on each solid fuel burning fireplace and stove shall include the following wording, "For use with solid fuel only" and "Approved for manufactured home use" or "Listed for manufactured home use," and contain the name of the manufacturer and listing agency, the model number, serial number, and listing number.

04. **Installation.** Installation of solid fuel burning fireplaces and stoves shall, at a minimum, conform to the terms of their listings, the fireplace or stove manufacturer's installation instructions, and the requirements prescribed in the following Subsections. **See Figure 1004.1.**

- a. A listed factory-built chimney designed to be attached directly to the fireplace or stove shall be used. The chimney shall be equipped with, and contain as part of its listing, a termination device and spark arrestor.
- b. The fireplace or stove air intake assembly, hearth extension, and chimney shall, at a minimum, be installed according to the terms of their listings and the fireplace or stove manufacturer's installation instructions.
- c. The combustion air inlet shall conduct air directly into the fire chamber and be installed to prevent material from the hearth dropping onto the area beneath the manufactured home.
- d. The fireplace or stove shall not be installed in a sleeping room.

e. A hearth extension shall be constructed of noncombustible material not less than three-eighths inch (3/8") thick.

f. The hearth shall extend at least sixteen inches (16") in front of, and at least eight inches (8") beyond each side of, the fireplace or stove opening and cover the entire surface beneath a stove or beneath an elevated or overhanging fireplace.

g. Fireplaces and stoves shall be secured in place to prevent displacement.

h. The chimney shall extend at least three feet (3') above that part of the roof through which it passes and at least two feet (2') above the highest elevation of any part of the manufactured home structure within ten feet (10') of the chimney. If a ramada is installed the chimney must conform to the requirements prescribed in **Subsection 908.05.**

i. Portions of the chimney flue, spark arrestor, and rain cap, shipped-loose for transportation purposes, shall, at a minimum, be installed on-site to the fireplace or stove manufacturer's installation instructions during the installation of the manufactured home.

j. Heat shields used with fireplaces or stoves shall have a minimum one inch (1") air space between the heat shield and any wall surface.

k. Fireplaces and stoves shall not be installed in alcoves unless specifically listed for use within alcoves.

l. Fireplaces and stoves shall be located so that no doors, drapes, or other such material can be placed, or swing closer, to the appliance than the clearances specified on the appliance label.

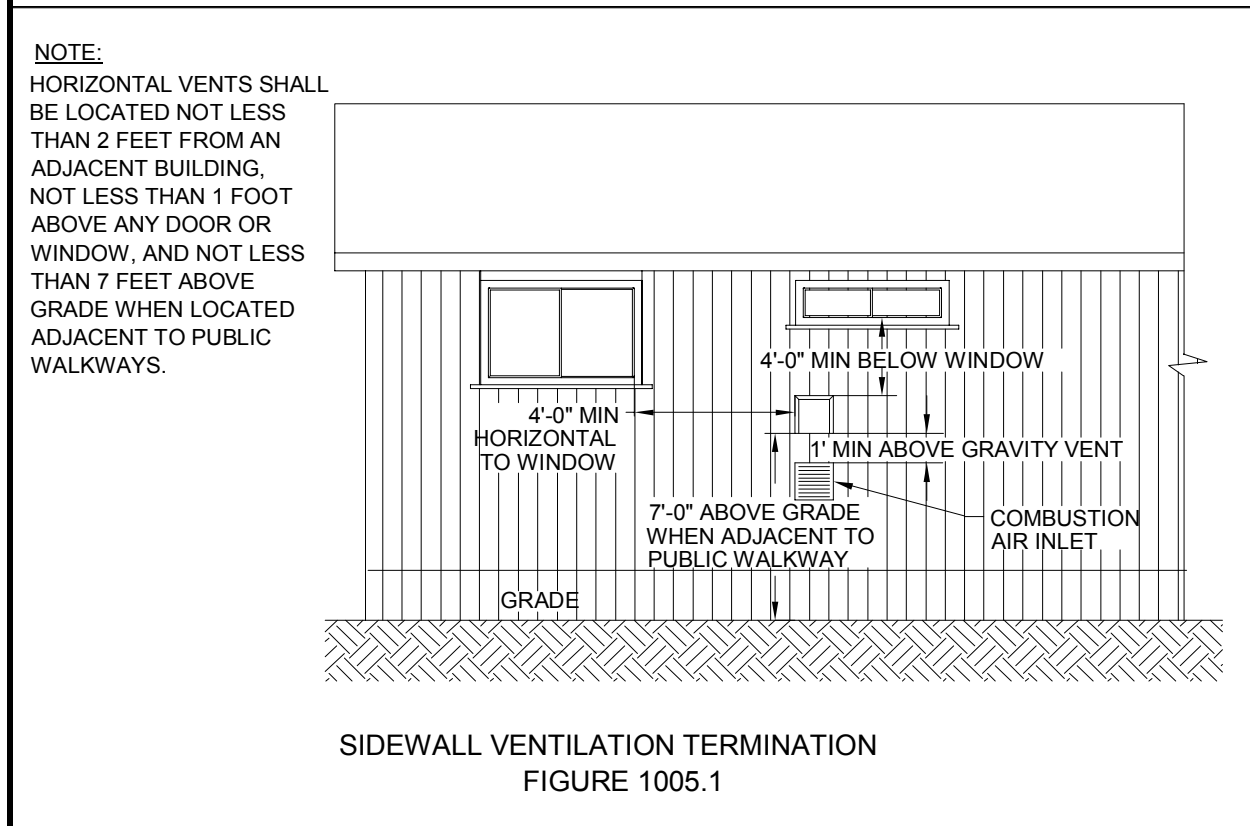
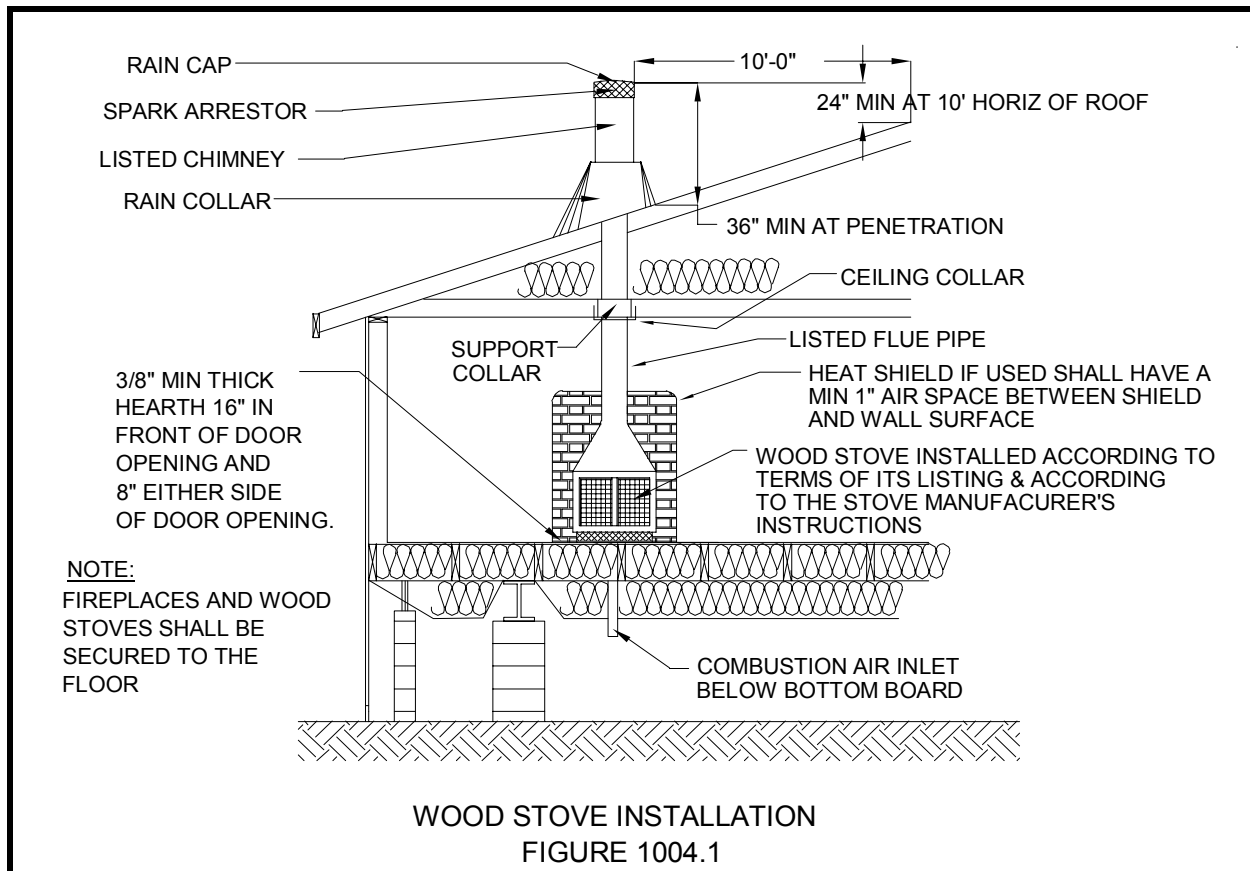

m. Clearances surrounding fireplaces and stoves shall not be less than the clearances specified in the terms of the listing; and

n. Combustion air shall not be taken from within any wall cavity, floor cavity, or ceiling cavity, or from any basement area.

1005. PELLETT FIRED APPLIANCES.

01. Installations. Pellet-fired appliances may be installed in manufactured homes provided such appliances and the installations conform to the following requirements.

a. Pellet-fired appliances shall not be substituted for the required heating facility.

b. The installation of each appliance shall, at a minimum, conform to the terms of its listing, the appliance manufacturer's installation instructions, and this standard.

c. Each appliance shall be secured in place to prevent displacement.

d. Each appliance shall be accessible and removable for purposes of servicing and replacement.

e. Pellet-fired appliances shall be located so that no doors, drapes, or other such material can be placed, or swing closer to, the appliance than the clearances specified on the appliance label.

f. Clearances surrounding pellet-fired appliances shall not be less than the clearances specified in the terms of their listings.

g. Pellet-fired appliance air intake assemblies, hearth extensions, and exhaust vents shall, at a minimum, be installed according to the terms of their listings, and the appliance manufacturer's instructions.

h. Combustion air shall not be taken from within any wall cavity, floor cavity, or ceiling cavity, or from a basement area.

i. Pellet-fired appliances shall not be installed in a sleeping room.

j. Hearth extensions, when required by the appliance listing, shall be of noncombustible material constructed, at a minimum, to the specifications included in the appliance listing and the appliance manufacturer's instructions.

k. Horizontal exhaust vents shall, at a minimum, be installed to conform to the terms of the appliance listing and the appliance manufacturer's instructions. Horizontal exhaust vent terminations shall be located not less than four feet (4') below, four feet (4') horizontally from, or one foot (1') above any window or gravity air inlet into any building, and not less than 2 feet from an adjacent building. Horizontal exhaust vents shall be installed not less than seven feet (7') above grade when located adjacent to public walkways.

See Figure 1005.1.

l. Vertical exhaust vents shall extend at least three feet (3') above the part of the roof through which they pass, and at least two feet (2') above the highest elevations of any part of the manufactured home within ten feet (10') horizontally of the exhaust vent. **See Figure 1004.1.** If a ramada is installed the vents must conform to the requirements prescribed in **Subsection 908.05.**

m. Portions of the exhaust vent and termination, shipped loose for transportation purposes, shall, at a minimum, be installed on-site according to the appliance manufacturer's installation

instructions during the installation of the manufactured home.

n. Every pellet fired appliance shall be accessible for inspection, service, repair, or replacement without removing permanent construction. Sufficient room shall be available to enable the operator to observe the burner, control, and means of ignition while starting the appliance.

1006. -- 1099. RESERVED.

DEFINITIONS

01. **Accessible.** Having access thereto, but which may require removal of an access panel or opening of a door.
02. **Accessory Building or Structure.** Any permanent structure established for use of the occupant of the manufactured home and as further defined by rule by the Division.
- a. **Accessory Building.** An accessory building including, but not limited to, ramadas, storage sheds, and garages.
 - b. **Accessory Structures.** An accessory structure including, but not limited to, awnings, carports, decks, steps, and ramps.
03. **Alteration.** Any change, addition, repair, conversion, replacement, modification, or removal of, any equipment or installation which may affect the operation, construction, or occupancy of a manufactured structure. Alteration does not mean:
- a. Minor repairs with approved component parts;
 - b. Conversion of listed fuel burning appliances according to the terms of their listing ; or
 - c. Adjustment and maintenance of equipment, or replacement of equipment or accessories in kind.
04. **Approved.** Approved, licensed, or certified by the Division of Building Safety or its designee.
05. **Attached Garage.** A garage which is joined to a manufactured home but is self-supporting and separated with fire-resistive construction.
06. **Authority Having Jurisdiction.** The local government which inspects and issues permits for installation, alteration, or conversion of manufactured homes, equipment, accessory buildings and structures.
07. **Awning.** Any stationary structure, permanent or removable, used in conjunction with a manufactured home for the purpose of providing shelter and having a roof with supports and not more than one wall. Window awnings are excluded from this definition.
08. **Base Flood.** Defined by FEMA in 44 CFR Chapter 1 as the flood level that has a one percent (1%) probability of being equaled or exceeded in any given year.
09. **Building Drain.** That part of the lowest piping of a drainage system which receives the discharge from soil, waste, and other drainage pipes inside the walls of the manufactured home and conveys it to the building sewer.
10. **Building Sewer.** That part of the horizontal piping of a drainage system which extends from the end of the building drain and which receives the discharge of the building drain and conveys it to a public sewer, private sewer, individual sewage disposal system, or other point of disposal.
11. **Building Supply.** The pipe carrying potable water from the water meter or other source of water supply to a building or other point of use or distribution on the lot. Building supply shall also mean water service.
12. **Carport.** A stationary structure consisting of a roof with its supports and not more than one wall used for sheltering a motor vehicle.
13. **Chassis.** The entire transportation system of a manufactured home.
14. **Clearance.** The distance between two adjacent surfaces.

15. **Concealed.** Rendered inaccessible by the structure or finish of the manufactured home.
16. **Controlled Fill.** Fill shall be engineered to bear a minimum one thousand five hundred pounds per square foot (1,500 psf) structural load in which the fill material is placed in layers of soil, crushed stone, or masonry waste material, compacted, and tested to ensure that it meets specified compaction standards determined by laboratory test of soil samples from the fill material.
17. **Division.** The State of Idaho Division of Building Safety.
18. **Drain.** A pipe that carries waste, water, or waterborne waste in a drainage system.
19. **Dwelling Unit.** One or more habitable rooms which are designed to be occupied by one family with facilities for living, sleeping, cooking, and eating.
20. **Equipment.** Materials, appliances, subassembly, devices, fixtures, fittings, and apparatuses used in the construction, plumbing, mechanical, and electrical systems of a manufactured structure.
21. **Feeder Assembly.** The overhead or under-chassis feeder conductors, including the grounding conductor, together with the necessary fittings and equipment, or a power supply cord approved for manufactured home use, designed for the purpose of delivering energy from the source of electrical supply to the distribution panel board within the manufactured home.
22. **Footing.** That portion of the support system that transmits loads directly to the soil.
23. **Foundation System.** A perimeter footing and stem wall support system.
24. **Foundation Set.** A manufactured home installed on footings and piers and which has the perimeter enclosed with a supporting permanent foundation footing and stem wall extending below the frost line.
25. **Frame.** The fabricated rigid substructure which provides considerable support to the affixed manufactured home structure both during transport and on-site. It also provides a platform for attaching the running gear assembly, the draw bar, and coupling mechanism to the home.
26. **Garage.** A structure located on a manufactured home site designed for the storage of motor vehicles.
27. **Gas Supply.** A listed connector designed for connecting the manufactured home to the gas supply source.
28. **Grade.** The fall (slope) in reference to a horizontal plane expressed in inches per foot length or as a percentage. One hundred percent grade equals twelve inches fall in one foot length.
29. **Grounded.** Connected to earth or to some conducting body that serves in place of the earth.
30. **Ground Anchor.** Any device at a manufactured home site designed to transfer manufactured home anchoring load to the ground.
31. **Ground Level Installation.** A manufactured home with a below-grade foundation system and a perimeter retaining wall or foundation which has earth back filled against it.
32. **Installation.** In relation to:
- Construction.** Work performed inside the home after it leaves the factory and which affects the arrangements and methods of construction of the home, the fire and life safety aspects of the home, and

- the electrical, plumbing, and mechanical equipment and systems of the home.
- b. **Siting.** Work performed outside the home to place it on its site. This includes work associated with the manufactured home support and tie-down system, structural work, work associated with the fire and life safety aspects of the home, work associated with electrical, plumbing, and mechanical equipment, work to make up utility connections, and the work to install skirting and steps.
33. **Installer.** Any individual licensed to install, set up, block, tie down, secure, support, or install skirting to manufactured homes.
34. **Labeled.** Equipment or materials used in the manufacture or installation of a manufactured home, to which has been attached a label, symbol, or other identifying mark of a nationally recognized testing laboratory, inspection agency, or other organization which evaluates products to nationally recognized standards and periodically inspects production of equipment and materials to show compliance with those standards for usage in a specified manner.
35. **Listing Agency.** An agency that:
- Is regularly engaged in conducting its own tests, listing, labeling, or contracting its testing procedures to a nationally recognized testing agency;
 - Maintains a periodic inspection program on production of currently listed products; and
 - Publishes, at a minimum, an annual report which is used to determine whether products have been tested to such national standards and found safe for use in a specified manner.
36. **Load Bearing Device.** Any equipment or device used in the support of manufactured home including but not limited to footings, piers, caps, and shims.
37. **Maintenance of Equipment.** Performing routine tasks such as lubricating or changing filters, washers, fuses, or bulbs as necessary for the continued operation of the equipment but does not include the replacement, conversion, alteration, or addition of any equipment.
38. **Manufactured Home.** A manufactured home or mobile home.
39. **Manufacturer's Representative.** An employee, dealer, or person authorized by a manufacturer through contract to act on behalf of the manufacturer.
40. **Minor Repair.** A simple repair such as replacing broken glass, fittings, devices, or fixtures, using approved component parts. This does not include the repair, replacement, conversion, alteration, or addition to, of major portions of the structural, plumbing, electrical, or mechanical systems of the manufactured home.
41. **Model.** An individual manufactured home as designated by the manufacturer, intended to be manufactured with a specific floor plan, structural components, and the type, location, and installation of plumbing, mechanical, and electrical equipment according to the plans submitted to the Design Approval Primary Inspection Authority.
42. **Municipality.** A city, county, or other unit of local government otherwise authorized by law to enact codes.
43. **Noncompliance.** A failure of a manufactured home, alteration, or installation to comply with an appropriate building code or standard.

44. **Option.** A provision made during the manufacture of a home to facilitate the future installation of any appliance other equipment (e.g., air conditioner, wet bar, or dishwasher).
45. **Pier.** That portion of the support system between the footing and the manufactured home.
46. **Porch.** A stationary structure which may be constructed with two (2) or more walls, used adjacent to, and in conjunction with, a manufactured home to provide additional space.
47. **Prefabricated Pier.** A listed or approved pier which is manufactured at an off site location but does not include concrete blocks.
48. **Ramada.** A stationary structure have a roof extending over a manufactured home which may also extend over a patio or parking space for motor vehicles, and is used principally for protection from snow, sun, or rain.
49. **Recessed Porch.** An open floor area supported by the main frame which is located outside the exterior walls of the manufactured home.
50. **Readily Accessible.** Direct access without the necessity of removing any panel, door, or similar obstruction.
51. **Repair.** The reconstruction or renewal of any part of an existing manufactured home or piece of equipment for the purpose of its maintenance (See alteration).
52. **Replacement In Kind.** Replacing equipment or accessories with approved like equipment or accessories, such as switches, thermostats, fittings, elements, or motors, but does not include the replacement of major portions of the structural, plumbing, electrical, or mechanical system.
53. **Service Equipment, Manufactured Home.** The equipment for connecting a manufactured home feeder assembly.
54. **Set Up.** See the definition of installation.
55. **Site, Manufactured Home.** A designated parcel of land designed to accommodate a manufactured home, its accessory structures or buildings, and accessory equipment for the exclusive use of the occupants.
56. **Skirting.** A weather resistant material used to enclose the space below the manufactured home.
57. **Stabilizing Devices.** All components of the anchoring system and support systems such as piers, footings, foundations, ties, anchoring equipment, ground anchors, and any other equipment which supports the manufactured home and secures it to the ground.
58. **Standard Set.** A manufactured home installed on footings and piers which has a perimeter enclosed by an above ground skirting or fascia.
59. **Support System.** A combination of foundations, footings, piers, caps, and shims that will, when properly installed, support the weight of the manufactured home.
60. **Tag.** A label or insignia issued by the Division and applied to manufactured homes to indicate compliance with federal or state laws, rules, and regulations.
61. **Testing Laboratory or Testing Agency.** An organization:
- In the business of testing equipment and systems;
 - Qualified and equipped to perform or to observe experimental testing to approved standards;

- c. Not under the jurisdiction or control of any single manufacturer or supplier for an affected industry;
 - d. Which publishes reports including specified information about the equipment and systems tested and found safe for use in a specified manner; and
 - e. Whose methods and standards have been approved by the Division.
62. **Tie.** Straps or securing devices used to connect the manufactured home to tie-down anchors.
63. **Tie-down.** Any device designed to anchor a manufactured home securely to the earth.
64. **Utilities.** The water, sewer, gas, or electric services provided on a lot for a manufactured home.
65. **Utility Connection.** Includes, but is not limited to, the following:
- a. Installation and connection of the manufactured home electrical feeders to the electric utility;
 - b. Installation and connection of the manufactured home drain to the sewer utility;
 - c. Installation and connection to the manufactured home water system to the water utility;
 - d. Installation and connection of the manufactured home fuel gas system to the gas utility.
66. **Vertical Tie.** A tie intended to resist the uplifting or overturning forces.
67. **Visual Inspection.** An inspection of the visible portions of completed construction for the purpose of identifying code compliance.

ACRONYMS AND ABBREVIATIONS.

The following list defines acronyms and abbreviations as they are used in this standard.

01. **ABS.** Acrylonitrile butadiene styrene.
02. **ADA.** Americans with Disabilities Act.
03. **ANSI.** American National Standard Institute.
04. **ASTM.** American Society for Testing and Materials.
05. **AWPA.** American Wood Products Association.
06. **CFR.** Code of Federal Regulations.
07. **CPVC.** Chlorinated polyvinyl chloride.
08. **DAPIA.** Design Approval Primary Inspection Agency. A state or private organization that has been accepted by the Secretary of HUD to evaluate and approve manufactured home designs and quality control procedures.
09. **FEMA.** Federal Emergency Management Agency.
10. **HUD.** US Department of Housing and Urban Development.
11. **IMHIS.** Idaho Manufactured Home Installation Standard.
12. **IPIA.** Production Inspection Primary Inspection Agency. A state or private organization that has been accepted by the Secretary of HUD to evaluate the ability of manufactured home manufacturers to follow approved quality control procedures and provide ongoing surveillance of the manufacturing process.
13. **NEC.** National Electrical Code.
14. **NFPA.** National Fire Protection Association.
15. **PEX.** Cross linked polyethylene tubing.
16. **PSI.** Pounds per square inch.
17. **PSF.** Pounds per square foot.
18. **PVC.** Polyvinyl chloride.
19. **UPC.** Uniform Plumbing Code.

SUBJECT INDEX

Access & Egress.	72	Connections.	53
Accessibility	75	Construction Standard.	73
Accessories.	68	Crossover Connection.	49
Accessory.	69	Crossover Ducts.	59
Accessory.	72	Decks, Porches, Landings, Stairs, Ramps, and Guardrails.	73
Accessory Buildings and Structures	69	Drain and Sewer Connections.	54
Administrative Appeals	1	Drain Test.	58
After Market Installations.	59	Drainage.	46
Alterations.	3	Dryer Exhaust.	75
Alternate anchoring systems	29	Dryer Exhaust Vents.	62
Alternate anchoring systems	47	Egress and Exit.	72
Anchoring	27, 46	Egress Requirements.	14
Appliance Compartment, Water Heater, Furnace.	76	Electrical Connections	49
Appliance Listing	76	Electrical Equipment	51
Appliance Venting	62	Electrical Feeder Connections	49
Approval.	9	Electrical Testing	51
Approved Installation Materials and Components.	10, 17, 31	Elevation.	13
Attached Garages.	69	Enclosed Exit Doors.	72
Attachment to Manufactured Home.	73	Enclosure.	68
Authority.	1	Enclosures.	72
Basement Perimeter Support Foundation.	45	End Wall and Interior Wall Connections	13
Block Pier Caps.	19	Equipment Support.	59
Block Pier Caps.	33	Erosion.	10
Block Pier Shims	21	Fees.	3
Block Pier Shims	33	Figures.	1
Block Pier Wedges.	21	Flood Resistance.	13
Block Pier Wedges.	34	Floor Access.	68
Block Piers.	19	Floor Connections.	11
Block Piers.	33	Flue Listing	76
Bonding Strap Removal	51	Footings.	17, 31
Carports & Awnings.	68	Foundations and Ground Level Access	67
Certification of Anchor Components	29, 47	Foundations for Existing Home	44
Chassis Bonding	49	Frost Line.	10, 17, 31
Chassis Removal	9	Furnaces, Gas Stoves, Water Heaters, & Gas Fireplaces	76
Chimneys and Flues	72	Grading.	10, 46
Clearances for Installation	72, 75	Height of Installation	27, 38
Close Up.	9	Inspection Approval	14
Code.	69	Inspection Criteria	3
Combustion Air.	76	Inspections.	3
Compliance	9	Installation and Alteration Permits	3
Component & Materials Specifications 10, 21		Installation Instructions.	4, 28, 75
Condensation Drains	59	Installation Standard.	7

SUBJECT INDEX

Installer.....	3, 53	Ramps & Guardrails.....	73
Labeling.....	76	Range Exhaust Vents.....	75
Lag Bolts.....	13	Ranges & Dryers.....	75
Licensing.....	1	Real Property Designation.....	46
Loads for Anchors.....	27, 46	Required Installations.....	73
Local Jurisdiction.....	3	Requirement for Egress.....	72
Location of Supports.....	22, 26, 35, 37	Ridge Beam Connections.....	11
Lumber or Polymer Stacked Pads.....	21	Roof Support.....	69
Main Frame Supports.....	21, 34	Sealing.....	13
Manufacturer's Installation Instructions.....	9	Securement.....	76
Marriage Line Connections.....	11	Separation for Fire Code.....	69
Marriage Line Supports.....	23, 35	Separation From Ground.....	9
Mechanical Connections.....	59	Service Clearances.....	49
Mechanical Equipment.....	59	Service Equipment Connection.....	49
Multiple Permits.....	3	Service Equipment on Manufactured Home.....	49
Obstructions.....	72	Sewer Clean out Access.....	56
Operating Instructions.....	75	Shimming.....	11
Original Exit Door.....	72	Ship-Loose Plumbing.....	53
Original Installations.....	59	Shipped Loose Equipment.....	51
Other Appliances.....	75	Site.....	10
Other Permanent Foundation Designs.....	44	Site Built.....	68
Other piers.....	21, 34	Site Inspection.....	3
Patching.....	13	Site Preparation.....	9
Pellet Fired Appliances.....	77	Skirting.....	65
Perimeter Foundations.....	65	Skirting Access.....	67
Perimeter Supports.....	22	Snow Loads.....	7
Perimeter Supports.....	35	Solid Fuel Burning Fireplaces & Stoves.....	77
Permanent Construction Requirements.....	15	Stairs.....	15
Permanent Foundation.....	38	Stairway Access.....	68
Permits.....	3, 53, 59	State.....	3
Permits and Inspections.....	46	Stove Construction Requirements.....	76
Plan Reviews.....	3	Suitability of Site.....	9
Plans.....	3	Table 400-A.....	26
Plumbing Assembly.....	56	Table 500-A.....	37
Plumbing Tests.....	57	Temporary Placement.....	9
Porches.....	69	Testing.....	11, 21, 28, 51
Power Supply.....	49	Tie Strapping.....	28, 47
Prefabricated Awnings & Carports.....	68	Underfloor Access.....	67
Prefabricated Piers.....	21	Underfloor Enclosures.....	13, 65
Prefabricated Piers.....	21, 34	Underfloor Ventilation.....	9, 65
Prohibited Construction.....	73	Unforeseen Factors.....	9
Prohibited Installations.....	59	Unique Installations.....	7
Railing Installation.....	15, 73	Unusual Installations.....	9
Ramadas.....	72	Utilities Inspection.....	4

SUBJECT INDEX

Vapor Retarder	10	Water Test	57
Venting	62	Water Utility Size	54
Wall Attachment	68	Water Valve Access	54
Wall Support	68	Windows and Doors	68
Water Connections	53	Written Interpretations	1

This page intentionally blank

FIGURE INDEX

(See also LIST OF FIGURES, Page xv)

Figure 301.1.....	7, 10, 17, 44	Figure 503.1.....	34, 36
Figure 301.2.....	7, 10, 31, 38	Figure 504.1A.....	38, 40
Figure 304.1.....	11	Figure 504.1B.....	38
Figure 304.2.....	11	Figure 504.1C.....	41, 42
Figure 304.3.....	11	Figure 504.2A.....	38, 47
Figure 304.4.....	13	Figure 504.2B.....	38, 47
Figure 304.5.....	13	Figure 504.3A.....	44
Figure 306.1.....	15	Figure 504.3B.....	44
Figure 402.1.....	17, 19, 23	Figure 504.3C.....	44
Figure 402.2.....	17	Figure 504.4A.....	45, 46
Figure 402.3.....	17	Figure 504.4B.....	45
Figure 402.4.....	17	Figure 505.1.....	47
Figure 402.5.....	17	Figure 603.1.....	49
Figure 402.6.....	19	Figure 605.1.....	51
Figure 402.7.....	19	Figure 605.2.....	51
Figure 402.8.....	19, 21, 27	Figure 703.1.....	54
Figure 402.9.....	19, 21, 27	Figure 703.2.....	54
Figure 402.10.....	21	Figure 704.1.....	56
Figure 403.1.....	21, 22, 23, 25	Figure 802.1.....	59
Figure 403.2.....	23	Figure 803.1.....	61
Figure 403.3.....	23	Figure 804.1.....	62
Figure 403.4.....	25	Figure 804.2.....	62
Figure 403.5.....	25	Figure 902.1.....	65
Figure 406.1.....	28	Figure 902.2.....	65
Figure 406.2.....	29	Figure 905.1.....	69
Figure 502.1.....	31	Figure 906.1.....	69
Figure 502.2.....	33	Figure 907.1.....	69
Figure 502.3.....	33	Figure 908.1.....	72
Figure 502.4.....	33	Figure 1004.1.....	76, 77
Figure 502.5.....	33, 34, 38	Figure 1005.1.....	79
Figure 502.6.....	34		